

88544_A



Q-Drive

Installation, Operation, and Maintenance Manual

Model: QGD and QGT



All trademarks used herein are the property of their respective owners.

© 2020 Haskel International, LLC. All Rights Reserved.

Haskel International, LLC

Telephone	818-843-4000
Website	www.haskel.com
Email for Sales	sales@haskel.com
Mailing Address:	100 East Graham Place Burbank CA 91502 USA

Contents

About This Product.....	v
Your Model Number and Serial Number	v
Symbols in This Manual	v
Limited Warranty	vi
Safety Instructions.....	1
Warnings	1
Cautions	2
Safe Transport	3
Lifting Instructions for Q-Drive	3
Introduction.....	5
Gas Section	6
Q-Drive Actuator.....	7
Coolant	7
Modes of Operation	7
Compressor Mode.....	7
Fill & Pause Mode	7
Fill & Stop Mode	7
User Interface	7
User Accounts	7
Symbols on the Screen	9
Performance.....	11
Specifications	11
Site Preparation and Inspection	12
Installation and Setup.....	12
Securing the Q-Drive System.....	13
Attaching Power Connections	13
Attaching the Process Gas Filter.....	13
Attaching Air, Gas, and Coolant Lines	14
Supplying the Oil for Lubrication	15
Using Q-Drive System.....	16
Before You Begin	16
Powering On the System.....	16
Logging In to the HMI	17
Configuring the User Interface (UI)	17
Running the Leak Test	19
Shutting Down the System	19
Purging the Gas Sections.....	19
Monitor the System	21

Monitoring the Gas Pressure at Inlet and Outlet	21
Monitoring the Gas Temperature	22
Monitoring the Coolant Temperature.....	22
Managing the System.....	22
About Alarms.....	23
Troubleshooting	25
Inspection and Preventive Maintenance	26
Inspection Schedule	26
Checking the Surface and Connections.....	26
Running the Blow-By Test.....	26
Checking Oil	27
Disassembling the Gas Section	27
Performing a Visual Inspection	28
Reassembling the Adapter Piece Assembly	28
Reassembling the Gas Section.....	34
Checklist for Inspection and Preventative Maintenance	35
About Service and Repair	36
Ordering Replacement Parts.....	37
Replacement Procedures	38
Re-Assembling Drive Rod Assembly	38
Replacing the Piston Seals	40
Replacing Oil Filter and Oil.....	41
Removing the Oil Filters	41
Installing New Oil Filters.....	43
Draining Oil from Actuator.....	44
Adding New Oil.....	45
Re-Assembling Drive Rod Assembly	46
Replacing the Tie Rods	48
Replacing Check Valves.....	49
Replacing Cooling Jacket.....	50
Points of Connections	51
List of Alarms	57
Errors.....	57
Warnings	58
Information Message	59

About This Product

This manual describes how to install, operate, and maintain the following models of the Haskel Q-Drive: Haskel, LLC reserves the right to make changes to the Q-Drive and its firmware that might not be documented in this manual.

Model	Type	Diameter of Gas Section (mm)	
		First stage	Second stage
QGT150-90	Two stage	150	90
QGT150-63			63
QGT90-63		90	63
QGD150	Double-acting	150	150
QGD90		90	90
QGD63		63	63

Your Model Number and Serial Number

In any service calls or to order parts, include the model, serial number, and firmware version. The serial number is located on the right side of the frame and on the Settings page of the screen. The Settings page also shows the current version of the system's firmware.

Model	Serial Number
-------	---------------

Symbols in This Manual



Indicates conditions that can cause damage to the equipment.



Indicates conditions that can cause injury.



Disconnect Power Before Servicing



Identifies the manufacturer



Electrical Shock Hazard



Hot Surface Hazard



Lockout/Tagout before servicing



Requires forklift to move.



Use two people to lift the component.

Limited Warranty

Haskel International manufactured products are warranted free of original defects in material and workmanship for a period of one year from date of shipment to first user.

This warranty does not include packaging, seals, or failures caused by lack of proper maintenance, incompatible fluids, foreign materials in the driving media, in the pumped media, or application of pressures beyond catalog ratings. Products believed to be originally defective may be returned, freight prepaid, for repair and/or replacement to the distributor, authorized service representative or to the factory, if upon inspection by the factory or authorized service representative the problem is found to be originally defective material or workmanship, repair or replacement will be made at no charge for labor or material, F.O.B the point of repair or replacement.

Permission to return under warranty should be requested before shipment and include the following: the original purchase date, purchase order number, serial number, model number, or other pertinent data to establish warranty claim, and to expedite the return or replacement to the owner.

If unit has been disassembled and reassembled in a facility other than Haskel, warranty is void if it has been improperly reassembled or substitute parts have been used in place of factory-manufactured part.

Any modification to any Haskel product which you have made or may make in the future has been and will be at your sole risk and responsibility, and without Haskel approval or consent. Haskel disclaims any all liability, obligation, or responsibility for the modified product, and for any claims, demands, or causes of action for damage or for personal injuries resulting from the modification and/or use or such a modified Haskel product.

HASKEL'S OBLIGATION WITH RESPECT TO ITS PRODUCTS SHALL BE LIMITED TO REPLACEMENT, AND IN NO EVENT SHALL HASKEL BE LIABLE FOR ANY LOSS OR DAMAGE CONSEQUENTIAL OR SPECIAL, OF WHATEVER KIND OR NATURE, OR ANY OTHER EXPENSE WHICH MAY ARISE IN CONNECTION WITH OR AS A RESULT OF SUCH PRODUCTS OR THE USE OR INCORPORATION THEREOF IN A JOB. THIS WARRANTY IS EXPRESSLY MADE IN LIEU OF ALL OTHER WARRANTIES OF MERCHANTABILITY AND FITNESS FOR A PARTICULAR PURPOSE. NO EXPRESS WARRANTIES AND NO IMPLIED WARRANTIES WEHTHER OF MERCHANTABILITY OR FITNESS FOR A PARTICULAR PURPOSE OR OTHERWISE, OTHER THAN THOSE EXPRESSLY SET FORTH ABOVE, SHALL APPLY TO HASKEL PRODUCTS.

Safety Instructions

- Use this system in strict accordance with all safety regulations. Follow all applicable national and regional regulations.
- Make sure the environment in which the machinery is to be used is safe for the processed media.
- Read and understand the operating instructions in this manual and all safety labels.
- A trained person must operate this system. Training includes instruction in operation under both normal conditions and emergency conditions.
- Qualified electrical personnel must perform installation and maintenance. Before opening the electrical control cabinets, turn off and lock out the main isolating switch. Be aware that live parts might be present. Replace any removed covers before restarting the system.
- Never start service or reach into the system unless the machine is locked AND tagged.
- Never change or defeat the function of electric interlocks or other machine shutdown switches.
- All protective earth wires must remain connected at all times.

Warnings



WARNING: Conditions that can cause injury.

- Never remove the warning tags or labels.
- Anyone in the vicinity of the system must wear the personal protection equipment (PPE): safety glasses, steel-toe shoes, protective/safety gloves, hard hat, and any equipment that is a site requirement.
- For an immediate shutdown, press the E-Stop button on the system.
- Use the site lockout procedure for power and start controls.
- Qualified electrical personnel must install and maintain the system.
- Do not open the Variable Frequency Drive Unit (VFD) until 5 minutes have elapsed after switching off the machine.
- The machinery will fault if the shop air drops below 4bars or exceeds 9.6 bars

Cautions



CAUTION: Conditions that can cause damage to the equipment.

- Be alert for high gas temperature and oil leaks. Alarms are not audible by default.
- Do not spray water on the system.
- Do not allow any metal to touch the inner surface of the gas barrel. Any scratch can cause immediate leaks after re assembly. The barrel must re honed.

Safe Transport

This work instruction is designed to ensure the consistent handling and shipping practices are used on Q-Drive units. Use this procedure to prepare unit for shipping and place unit in shipping container.

Tools	Purpose
PPE	Required for Operator Protection
Forklift (with extended forks)	To lift and move unit/crate
Hand Tools (impact driver) and hardware	To install parts and close crate

Lifting Instructions for Q-Drive

1. On the sides of the unit, at the bottom, there are 2 locations that are present for forklift forks to be inserted.

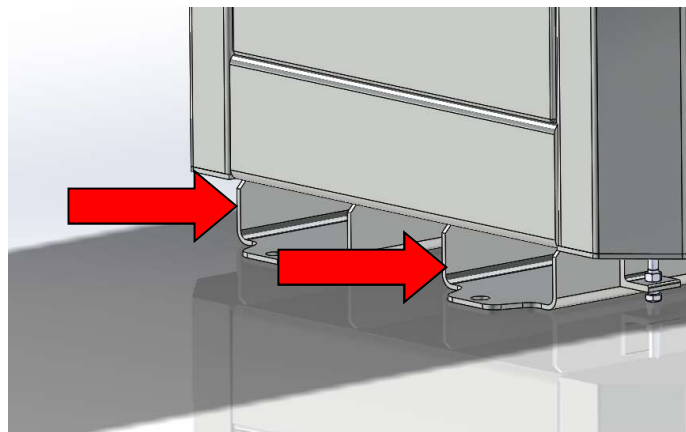
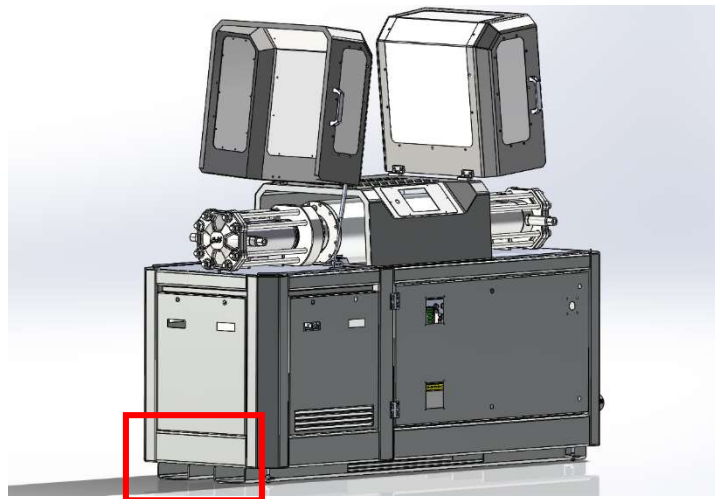

2. Also at the bottom on the front of the unit, the unit can be lifted from.

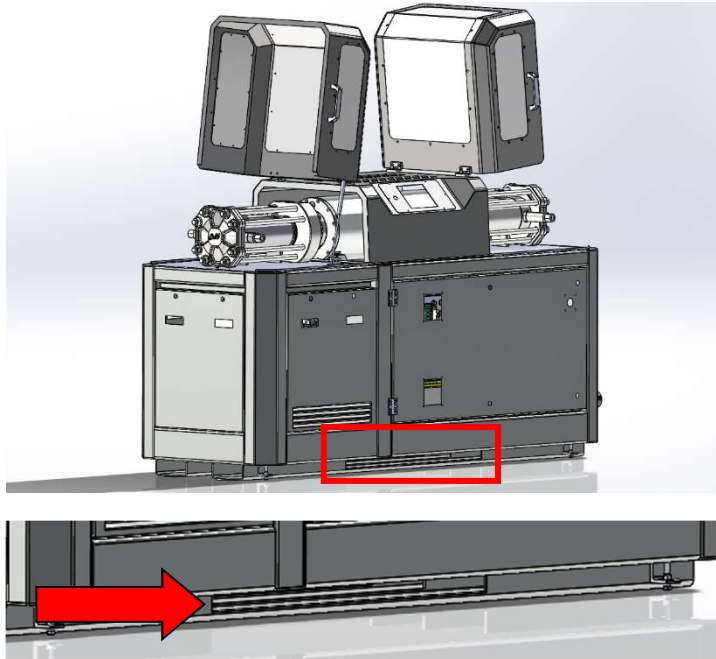

3. Once the forks are inserted, the unit can be lifted and transported as desired.

****NOTE**:** Only individuals with a Forklift Driving License (which requires classroom and practical training/testing) can use the Forklift.

Introduction

The Haskel Q-Drive system is a Gas Booster driven by electricity that pumps gas from a supply vessel, increases the gas pressure, and then delivers the gas to a pipeline or another vessel. See “Performance” section for the maximum gas pressure for each model.

- The QGD models are double-acting Gas Boosters, in which pistons both retract and extend.
- The QGT models use two-stage compressors that compresses the gas two times.

The drive is housed in a cabinet that manages and monitors power, gas, and air supplies.

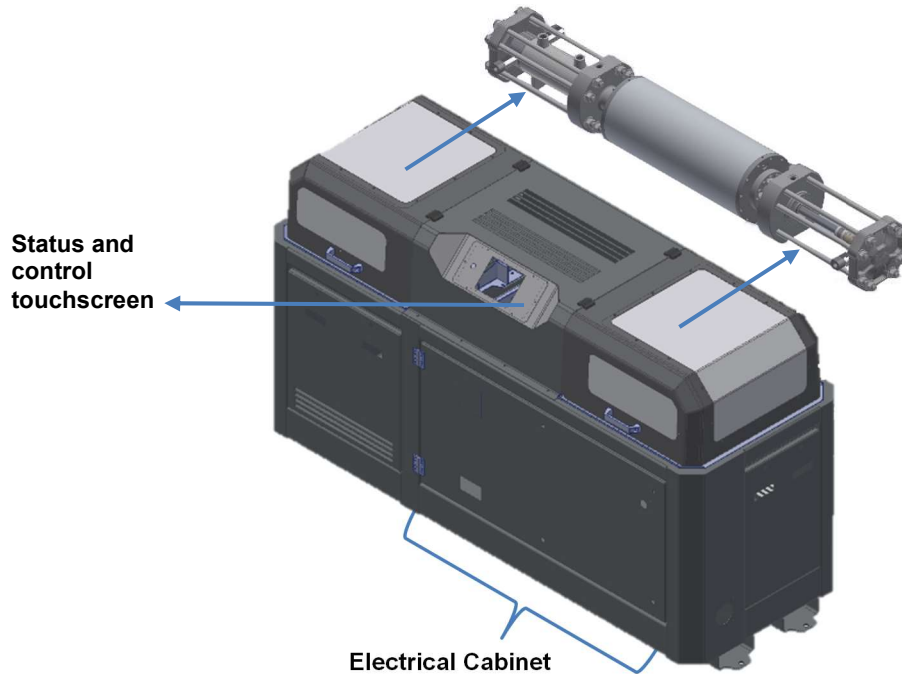

Isometric View of Q-Drive

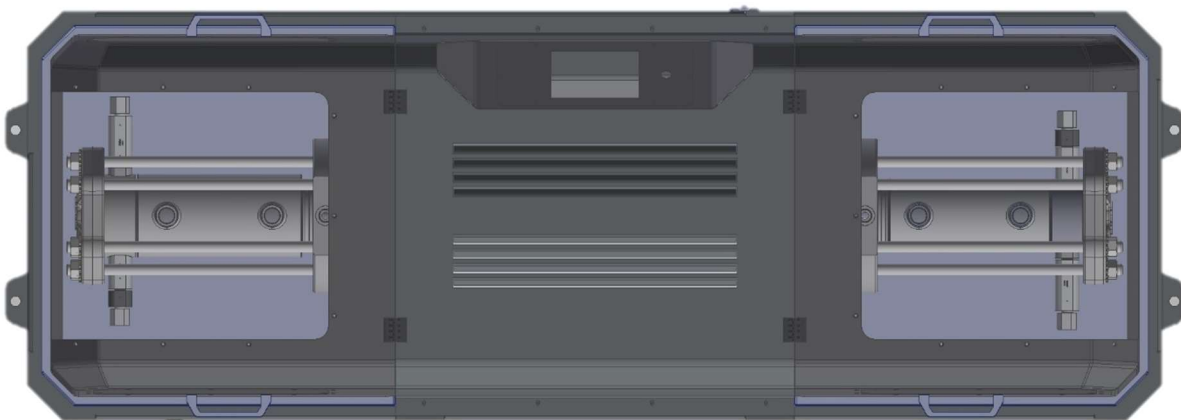

Top View of Q-Drive

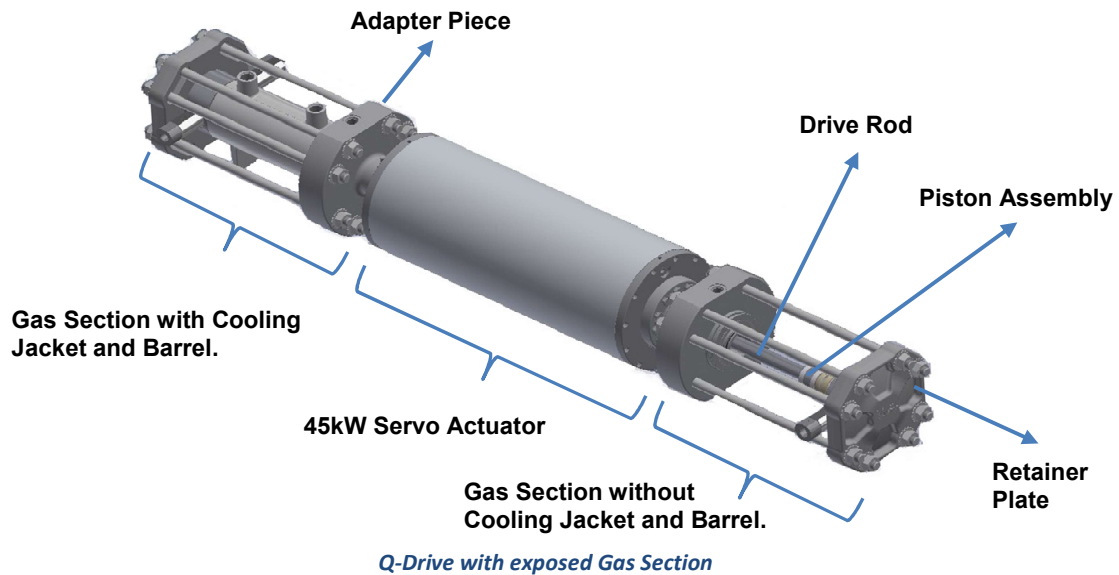

Gas Section

Each gas section boosts the inlet pressure independently through a common gas inlet.

The Compression Ratio (Cr) is the ratio of Outlet Pressure to Inlet Pressure. The maximum Compression Ratio for the Q-Drive system is 5. Higher Cr increases the gas temperature, but contribute to early failure of Piston Seals. Piston Seals are also affected by the Cycle Rate, the purity of the gas, and the type of operation.

Tie Rods hold the components of the Gas Section together. These Tie Rods must be tightened to the proper torque. Each Cooling Jacket has a label that shows the tightening pattern and required torque for each tie rod.

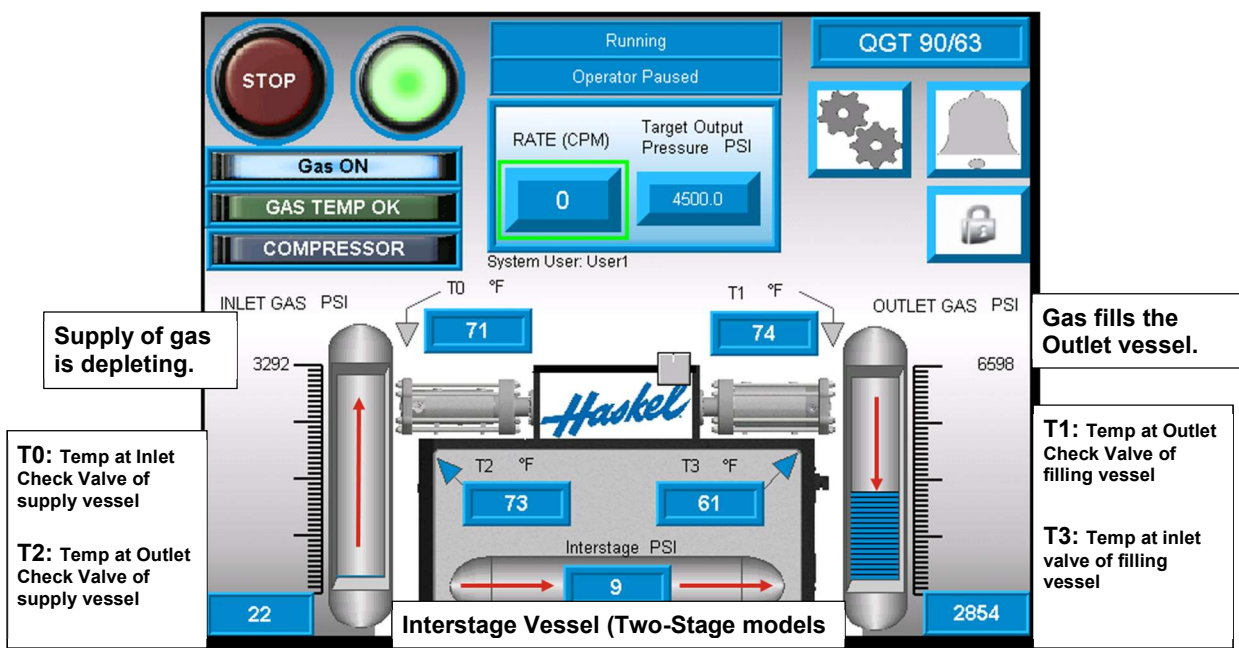

Flow of gas from supply vessel to filling vessel.

Q-Drive Actuator

To increase gas pressure, the electrically-driven Actuator moves the Drive Rods in the Gas Sections.

Coolant

Circulating coolant draws heat from the gas sections and the lubrication circuit. A Chiller must be connected to the coolant ports. The capacity needed for the Chiller depends on your application. Consult with Haskel representative for specific recommendation for your application.

Modes of Operation

Three modes of operation control the way the system functions.

Compressor Mode

The most common mode is to run the system continuously, depleting the inlet gas vessel and filling the outlet gas vessel. The pump runs until the gas pressure reaches the value of the Target Output Pressure and then stops until the gas pressure decreases to the deadband value that is set by user. The deadband is the range of pressure values in which no operations occur. At the deadband value, the pump restarts and increases the gas pressure to restore it to the target pressure.

Fill & Pause Mode

The pump runs until the gas pressure reaches the value of the Target Output Pressure and then pauses. The system is still running and gas is still in the system, but the pump is paused. To restart the pump, tap the Ack button .

Fill & Stop Mode

The pump runs until the gas pressure reaches the value of the Target Output Pressure and then stops. The air-actuated valves block the inlet and outlet pressure and vent the Q-Drive system. The compression is now concluded.

User Interface

A Programmable Logic Controller (PLC) monitors temperature and pressure of the non explosive process media throughout the system. The Human-Machine Interface (HMI) connects to the PLC to display the values on the touchscreen and allows you to make changes. You can view the status and current values at any time, but you must log in to the HMI to make changes.

The HMI screen is a touchscreen where user can see a button or icon, tap the screen to simulate pressing it.



Buttons or icons that have the appearance of height indicate a value user can change.



Areas of the screen that have a recessed appearance indicate a current value of live data that user cannot change.

User Accounts

The HMI has 3 standard accounts:

- The Supervisor account can make any changes to the operation of the system.
- The Operator account can stop and start operations, but cannot change parameters:
- The Service account can reset the counters after preventive maintenance.



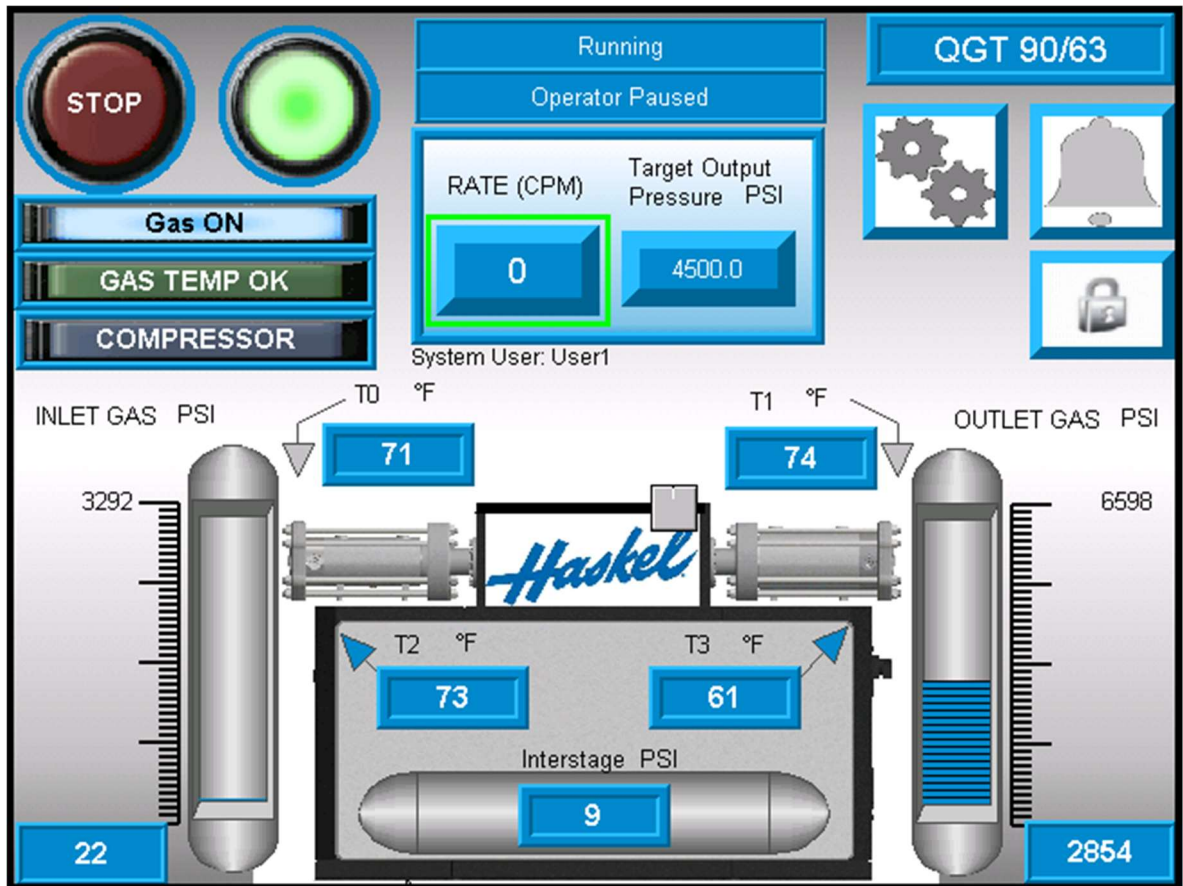





After you log in, you see the home screen for your model of the Q-Drive model.



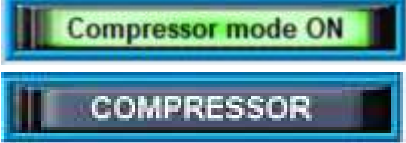
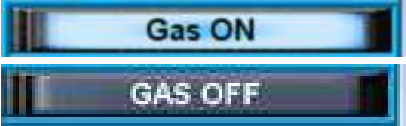



Example of the Home screen (for Two-Stage)

The screens in the user interface use the following symbols for indicators and buttons.

Symbols on the Screen

Symbol	Definition
	<p>Banner reports status: Running = pumping and compression in process Off Ready = Pump is in Stop condition and ready to be started. Off Not Ready = there is an active alarm, refer to your alarms. Operator CPM Limit = Operator is in control of Cycle Rate.</p>
	<p>The Start button is not displayed until you log into the system. While the system is running, the Start button is illuminated green. The Stop button is on every screen.</p>
	<p>Status indicator for pump.</p>
	<p>Status indicator for the mode of operation. Compressor Mode is the most common mode. Other modes are “Fill & Pause” and “Fill & Stop.”</p>
	<p>Status indicator for whether gas is in the system.</p>
	<p>Status indicator for gas temperature. When the temperature is too high, the indicator changes to High Gas Temp and flashes red.</p>
	<p>Home button is on every screen.</p>
	<p>Displays the Settings screen.</p>
	<p>Alarm button displays the Active Alarm screen.</p>
	<p>Up and down arrows scroll the alarm log.</p>
	<p>Logs out the current account while the system continues to run. To make changes, tap the Locked button to log in again.</p>

Symbol	Definition						
	<p>Pauses the pump temporarily, regardless of operating mode, but does not vent or isolate the system.</p>						
	<p>When using Fill & Pause mode, the Ack button restarts the pump.</p>						
	<p>Set or change the Cycle Rate, Cycles per Minute (CPM). The button shows the current value.</p>						
	<p>Set or change the target output pressure for the gas (BAR/psi).</p>						
<p data-bbox="277 600 516 632">Current Unit Select</p> 	<p>Set or change the temperature scale. When you select C, the pressure units change to the metric bar; when you select F, the pressure units change to psi.</p>						
<p data-bbox="305 726 483 758">Stroke Force</p> <table border="1" data-bbox="240 762 548 842"> <tr> <td></td> <td data-bbox="326 768 407 789">Reverse</td> <td data-bbox="440 768 521 789">Forward</td> </tr> <tr> <td data-bbox="256 804 289 825">kN</td> <td data-bbox="334 804 399 825">12.4</td> <td data-bbox="456 804 521 825">93.6</td> </tr> </table>		Reverse	Forward	kN	12.4	93.6	<p>Displays the current stroke force during running. The forward stroke pushes to the right and the backward stroke pushes to the left. The maximum force is 150 kN (33,721 lbf), which usually occurs at maximum gas pressure.</p>
	Reverse	Forward					
kN	12.4	93.6					

Performance

Model	Minimum Inlet psi (bar)	Maximum Inlet psi (bar)	Maximum Outlet psi (bar)	Maximum Recommended Compression Ratio (Cr)	Minimum Speed (CPM)	Maximum Speed (CPM) ¹	Maximum Stroke Force (kN) / lbf
QGT150-90	75 (5)	440 (30)	3400 (234)	25	1	40	150 / 33,721
QGT150-63	75 (5)	220 (15)	6600 (455)	25	1	40	150 / 33,721
QGT90-63	75 (5)	1500 (104)	6600 (455)	25	1	40	150 / 33,721
QGD150	75 (5)	1150 (80)	1150 (80)	5	1	40	150 / 33,721
QGD90	75 (5)	3400 (235)	3400 (235)	5	1	40	150 / 33,721
QGD63	75 (5)	6600 (455)	6600 (455)	5	1	40	150 / 33,721

¹ Consult Haskel representative for higher speed and pressure requirements.

Specifications

Physical Environment

Dimensions 98 in L x 34 in W x 54 in H
2.5 m L x 0.86 m W x 1.4 m H

Weight 2500 lbs (estimated max)
1134 kgs

Noise Level 77.0 dB(A)

Connections (Haskel International recommends BuTech 3/4 in M/P fittings and tubing.)

Blow By 3/4 in tube OD, 316 SST

Purge 1/4 in tube OD, 316 SST

Vent Lines 3/8 in tube OD, 316 SST

Gas Outlet and Inlet 1/2 in tube OD, 316 SST

Air Supply 1/2 in NPT female, brass for 80-120 psi
0.04 SCF at 100 psi (shop air)

Coolant Outlet and Inlet 1/2 in BSPP female

Coolant System

Maximum Pressure 150 psig (10.3 barg)

Coolant Ratio 80% glycol: 20% water by volume

Coolant Flow 14 usg/min (3.18 m3/hr)

Electrical System

Heating Power 3-Phase 380-480 V

Supply Current 60 A

Frequency 50-60 Hz

Lubrication System

Oil type Syn-Gear EP150

Capacity 30 litres (8 gallons)

Gas Temperature

Maximum Temperature 370 °F (188 °C)

Minimum Temperature at Inlet 32 °F (0 °C)

Operating Environment

Ambient Temperature	32—131 °F (0—55 °C)
Ambient Humidity	0-95%
Storage/Shipping Environment	
Ambient Temperature	-13—158 °F (-25—70 °C)

Site Preparation and Inspection

Before delivery, plan the site for the system to avoid problems and expense of delays.

- Choose an orientation that maintains alignment with machinery, power, and lines.
- Allow a minimum of 2 ft (0.6 m) of clearance space on all sides and 4 ft (1.2 m) on front side of the system.
- Allow a minimum of 3 ft(0.9 m) of clearance space above the system (above the hoods).
- Allow space for a catch tray and for access to plugs and to remove the system.
- Plan the location and depth of the anchor bolts.
- Prepare the electrical requirements listed in the “Specifications” table.



At delivery, inspect the exterior packaging for any damage or any signs of tampering such as broken security seals. As you unpack the system, look for unusual dents or punctures. Use the following procedure if you find damage.

1. Note the damage or loss with the exact exception on the Proof of Delivery.
2. Take photographs of the damage to external packaging, evidence of tampering, or broken security seals. Keep all damaged product and packaging for a possible inspection.
3. Go to the [Field Evaluation Report](#) and fill out the report within 14 days of delivery. Send the report and following information to the Haskel regional sales office:
 - Photographs and a description of the damage.
 - Estimate of damage or loss.
 - Written Proof of Delivery with the noted exceptions.

Checklist

<input type="checkbox"/>	Surface is clean, dry, and level.
<input type="checkbox"/>	Space around and above the system is sufficient.
<input type="checkbox"/>	Location of holes for anchor bolts is correct.
<input type="checkbox"/>	No shipping damage.

Installation and Setup



CAUTION: Qualified electrical personnel must perform installation and maintenance.

Securing the Q-Drive System

The drive requires 4 anchor bolts. The mounting holes are 21.8 mm (0.866 in) in diameter.

1. Insert the 4 anchor bolts. Do not lubricate.
2. Level the system.

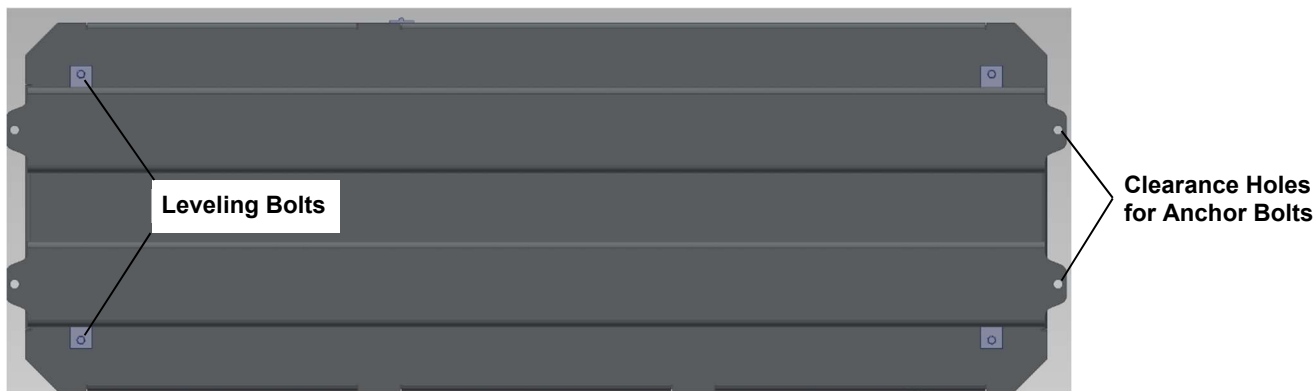

Bottom View of Q-Drive with Location of Anchor Bolts

Attaching Power Connections

Use a Mennekes® 3 Phase twist-lock connector.



Mennekes® 3 Phase twist-lock connector

Attaching the Process Gas Filter

The owner is responsible for filtration of any inlet process media to the QDRIVE system.

- The filter should not have more than 1% pressure drop across it @ the flowrate (in order not to lose incoming media pressure).
- The filter should be rated for the incoming media pressure and temperature.

- The filter needs to be @ 10 micron rating

Attaching Air, Gas, and Coolant Lines

Port	Connection	Port ID
Blow By	BULK 3/4" TUBE X 3/4" FEM NPT	1
Purge	BULK 1/4" TUBE X 1/4" FEM NPT	2
QGT Vent Lines (4)	BULK 3/8" TUBE X 3/8" FEM NPT	3
QGD Vent Lines (3)		
Gas Outlet	BULK 1/2" TUBE X 1/2" FEM NPT	4
Gas Inlet	BULK 1/2" TUBE X 1/2" FEM NPT	5
Air Supply	STRAIGHT BULKHEAD 1/2" FEM NPT	6
Coolant Outlet	3/4" JIC37 BULK FEM	7
Coolant Inlet	3/4" JIC37 BULK FEM	8
Drain Hole	1/4" TUBE OD	9

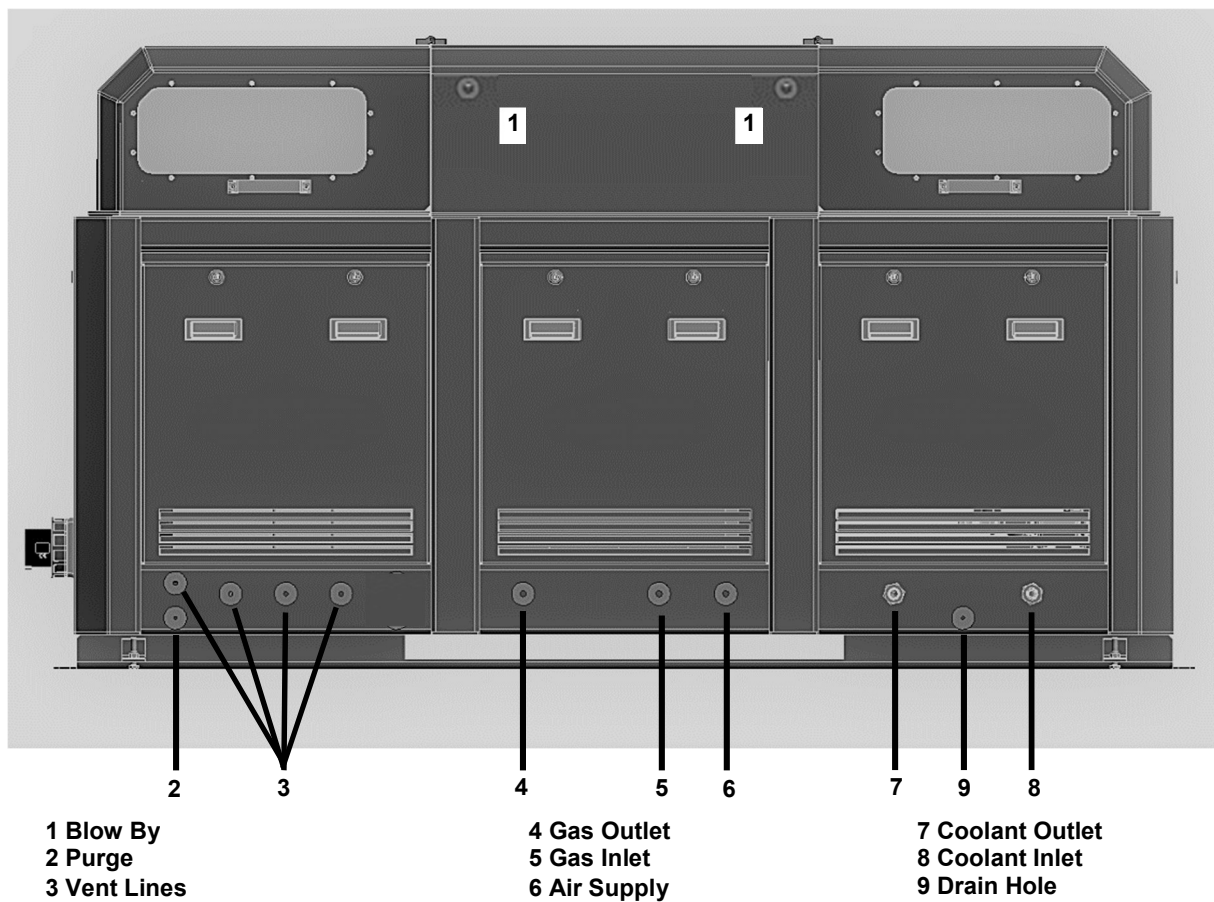

Ports on the Rear Side

Supplying the Oil for Lubrication

The Q-Drive system ships without lubrication. To supply oil for lubrication, use the procedure in “Adding New Oil.”

Using Q-Drive System



WARNING: Anyone in the vicinity of the system must wear the personal protection equipment (PPE): safety glasses, steel-toe shoes, protective/safety gloves, hard hat, and any equipment that is a site requirement.



CAUTION: Do not start any testing, maintenance, or service procedures while the system has positive power. Isolate the inlet gas source, outlet gas, and vent to atmospheric pressure before starting any procedure.

Before You Begin

Before you turn on the power for the system, check the lubrication level. The motor housing has 2 sight glasses through which you can view the oil level. When the system is not running, check the oil level in both glasses. If the oil level is not sufficient, add more oil. See “Adding New Oil.”



Sight glass for oil level in motor housing

Powering On the System

1. Connect high voltage supply. Turn on the power switch to power the system.

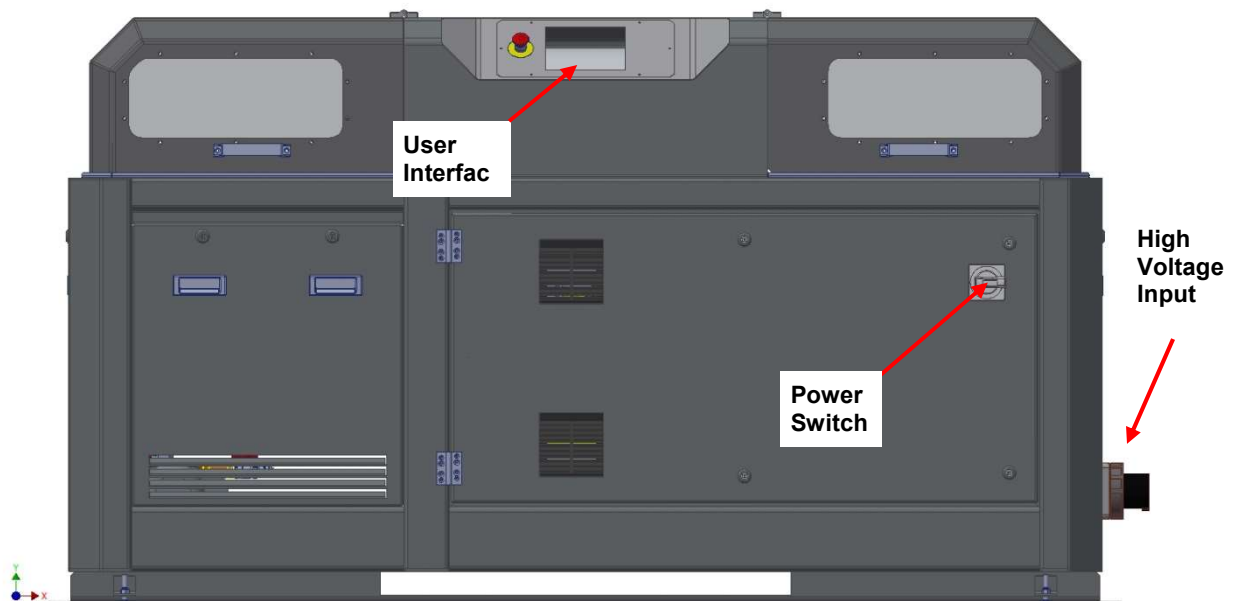

Front View of Q-Drive

Logging In to the HMI

1. Tap **Please Login**. The Login window displays:
2. Tap **User Name**. A popup keyboard displays so that you can enter the user name.
3. Tap the **Password** button and enter each character in the password.

4. Tap the **Login** button or the **Enter** key () on the keypad to log in.

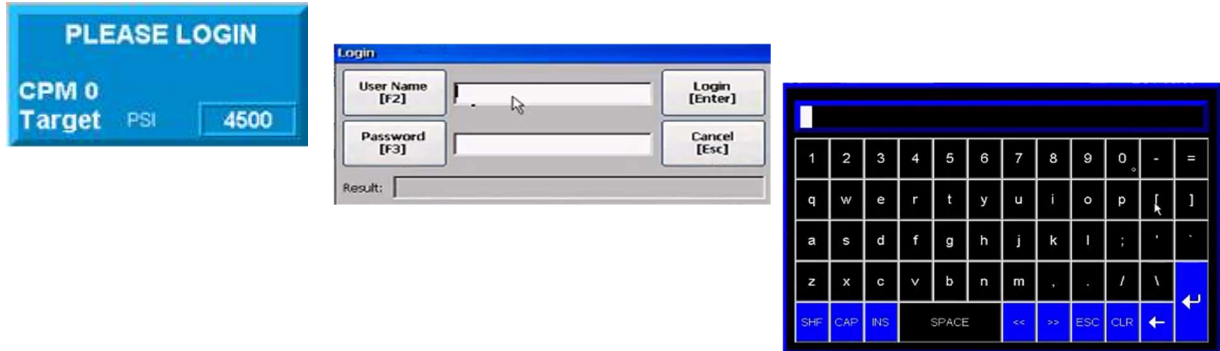

After you log in, you see the home screen for your model of the Q-Drive model.

Configuring the User Interface (UI)

1. On the home screen, tap **Settings**. On the Settings screen, tap **Supervisor Parameters**.
2. The first time you log in, configure the units that the UI uses to display data. In the **Current Unit Select** section, tap the temperature units button to toggle between metric units and imperial units.

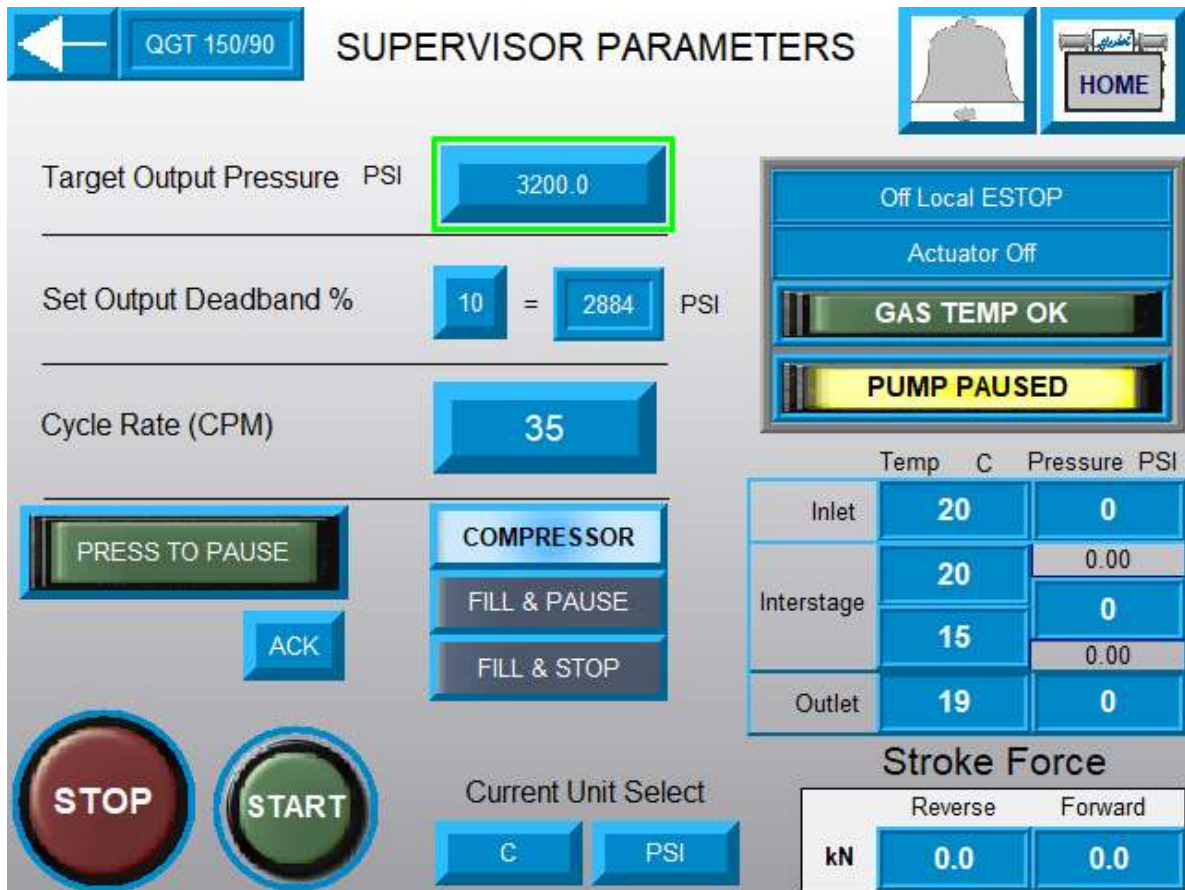

Supervisor Parameters screen

3. Tap one of the modes of operation. The Compressor mode is for continuous operation.
4. For all modes, set the Target Gas Outlet Pressure. Tap **Target Output Pressure** to display the numeric keypad. Enter the value and tap the **Enter** key .
5. For Compressor mode, set the deadband value to maintain the pressure level. Tap **Output Deadband %**. In the keyboard, enter the percent decrease from the target output pressure that is allowed.
When the pressure reaches the target pressure, the pump pauses and the status becomes **PUMP IS PAUSED**. While the pressure remains within the desired deadband, the pump remains paused. When the gas output pressure drops below the desired deadband, the pump restarts and the status is **RUNNING**.
6. To set the pump speed, enter your desired **Cycle Rate** button.
7. Open the valve on the supply gas gradually to load the gas slowly.
8. When the status is **Off Ready**, tap the **Start** button. If the status is **Off Not Ready**, check the active alarms. See “About Alarms.”

Running the Leak Test

It's highly recommended to the user to perform the leak test when operating the system, especially each time the system is turned on.

1. When the system is running, tap **Settings** and **Operator Parameters**.
2. Tap **Press To Pause** to pause the pump.
3. To check for gas leaks, increase the supply gas pressure to 500 psi.
4. Wait up to 2 minutes for the Non-Explosive Process Media to equalize.
5. Bubble Test the system for Non-Explosive Process Media leaks.
6. Check for coolant leaks by visual inspection.
7. Bubble Test for air leaks in the shop air supply line to the system.

Shutting Down the System

1. Tap the **Stop** button on any screen, which does the following:
 - Stops the pump and returns the pistons to park position.
 - Isolates inlet and outlet Non-Explosive Process Media.
 - Vents the system.
2. Close the air supply valve.
3. Close the coolant supply valve.
4. Turn off main power switch.

Purging the Gas Sections

Purging the system is typically done after maintenance of the Gas Sections, or for some applications, after each run. The purging does not have to be done unless it is desired. The following two procedures describe alternate methods of purging. Before you begin, the maximum inlet pressure is 200 psi (13.8 Bar).

If desired to purge with media other than process media, then follow this procedure:

1. Locate the purge port at the rear of the system. See "Attaching Air, Gas, and Coolant Lines."
2. Open the left panel of the cabinet and locate the Needle Valve.
3. Be sure to isolate the Main Media Inlet port.
4. Turn on the power.
5. Log in using the Service account.
6. Tap **Settings**, then tap **Service**.
7. On the Service screen, tap **Press to Pause**.
8. Press Start.

9. Tap **Press to Purge**. The inlet valve remains open and the outlet valve changes to vent. The purging process will not begin until inlet pressure is less than 200 psi (13.8 bar).
10. Go to the open panel and open the needle valve slowly. The purging Media will enter the inlet valve, flow through the gas sections, exit out of Gas Outlet vent.
11. When purging is complete, close the needle valve. Then **Press to Purge** button turns off.
12. On the Service screen, tap **Press to Pause** to restart the pump.
13. Shut down the system. See “Shutting Down.”

If not using a different Non-Explosive Process Media, then follow this procedure:

1. Locate the Inlet port. See “Attaching Air, Gas, and Coolant Lines.”
2. Turn on the power.
3. Log in using the Service account.
4. Tap **Settings**, then tap **Service**.
5. On the Service screen, tap **Press to Pause**.
6. Tap **Press to Purge**. The inlet valve remains open and the outlet valve changes to vent. The purging process will not begin until inlet pressure is less than 200 psi (13.8 bar).
7. Supply Non-Explosive Process Media slowly to the Gas Inlet port. The Process Media will enter the inlet valve, flow through the gas sections, exit out of Gas Outlet vent.
8. When purging is complete, stop supplying. **Press to Purge** button turns off.
9. On the Service screen, tap **Press to Pause** to restart the pump.
10. Shut down the system. See “Shutting Down.”

Monitor the System

It is possible to monitor the system from either the Home screen or the Operator Parameters screen. Both screens have the same information, but the Home screen is a visual representation of the current state of the system. However, to change a value you must log into a Supervisor account.

Monitoring the Gas Pressure at Inlet and Outlet

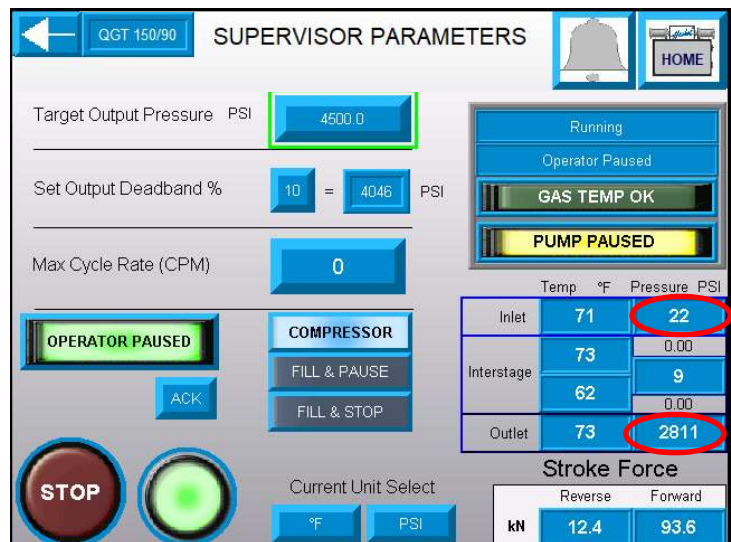
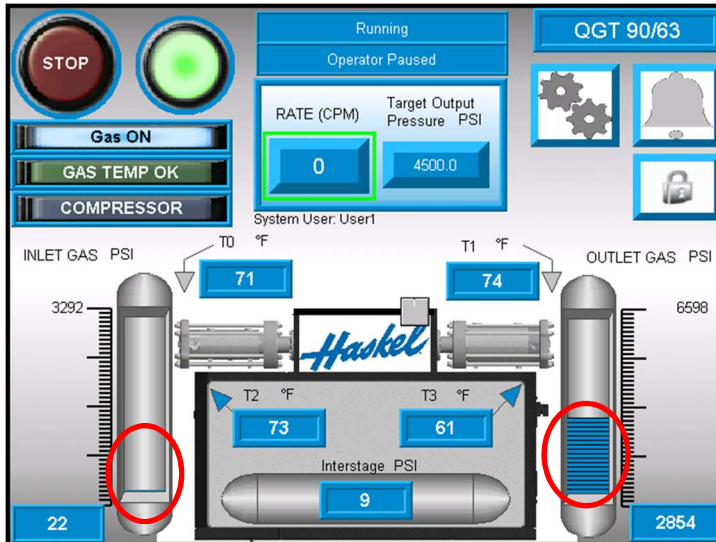

Comparison of Home Screen and Supervisor Parameters Screen for Gas Pressure

Monitoring the Gas Temperature

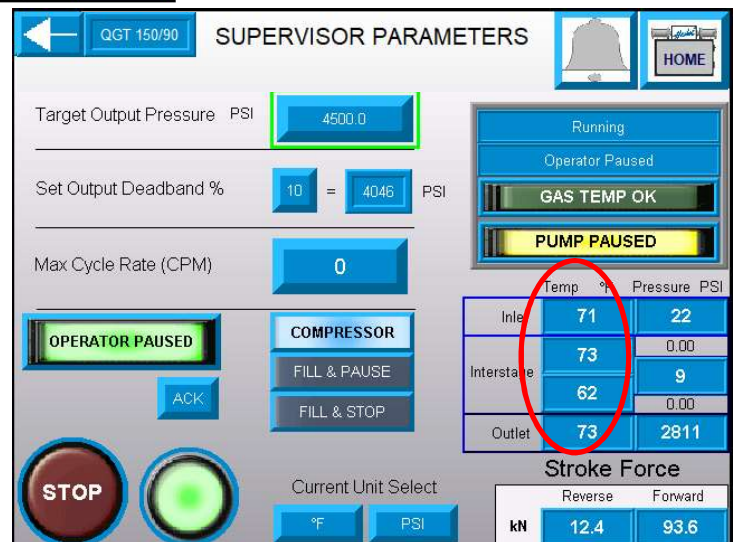
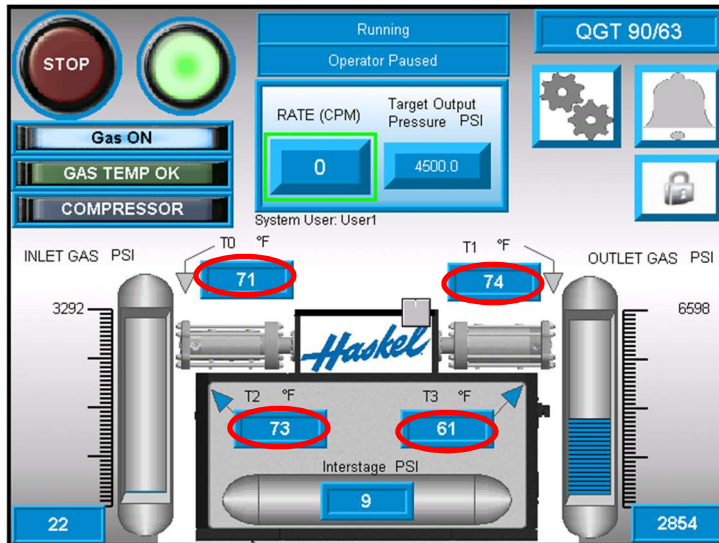

Comparison of Home Screen and Supervisor Parameters Screen for Gas Temperature

Monitoring the Coolant Temperature

If the coolant temperature increases, it means the coolant cannot dissipate the heat from the gas and is becoming insufficient to continue cooling. The Q-Drive system does not monitor the coolant temperature. You must monitor the coolant temperature by an external means and keep the temperature within recommended values.

Managing the System

To change the values in a running system, you can adjust the following:

- Cycle Rate
- Target Pressure
- Deadband %

About Alarms

In most cases, an alarm stops or pauses the pump. The alarm banner pops up on any screen. The following is an example of an alarm.

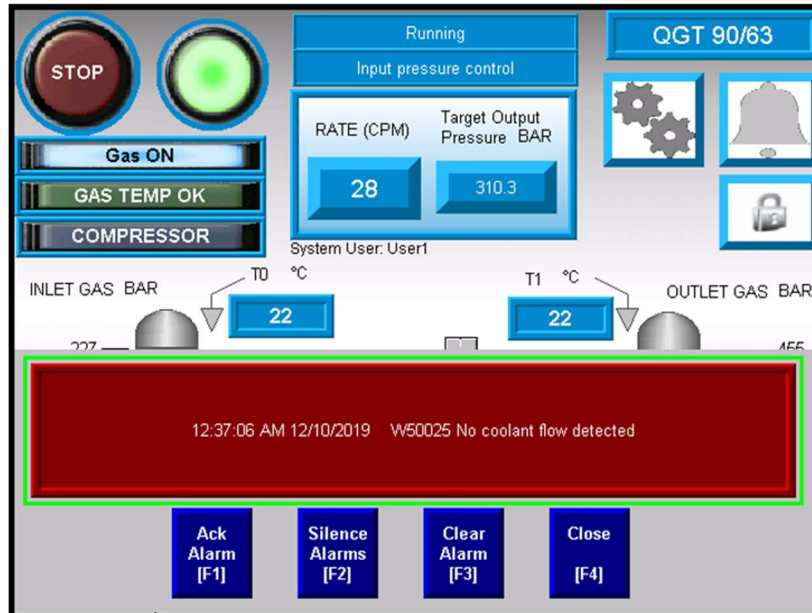

Alarm example



1. To see all current alarms, tap the Alarm icon to display the Active Alarm screen.

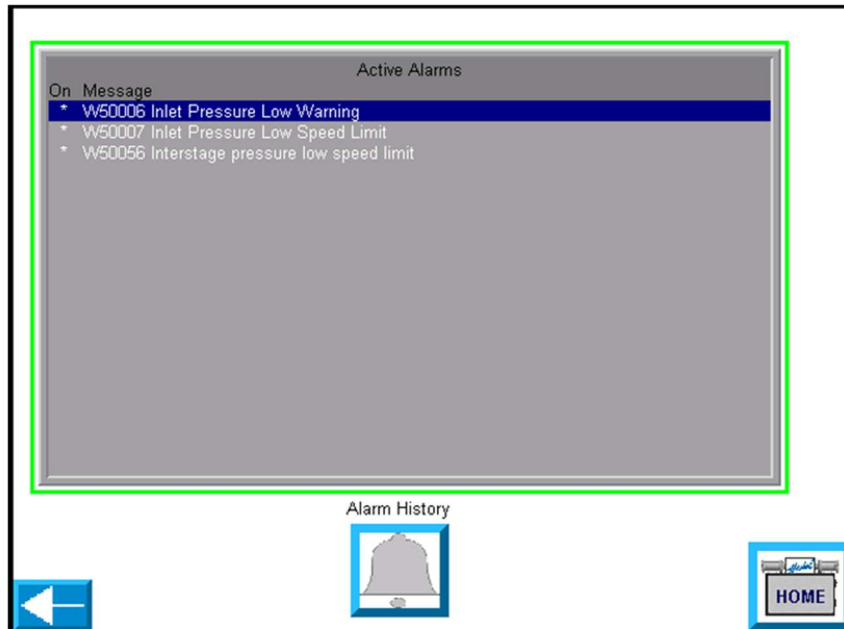

Alarm screen

2. See “Troubleshooting” to remove the alarm condition. When your changes cause the value to return to an acceptable value, the pump restarts.
3. All alarms are logged when they occur and when they are acknowledged. Tap **Alarm History** to see all alarms. Alarms are color-coded:
 - **Blue:** Informational
 - **Orange:** Warning. The parameter’s status is approaching a fault condition. The system can continue running but some adjustment is needed.
 - **Red:** Fault Error. The system protects its components by performing the appropriate action.

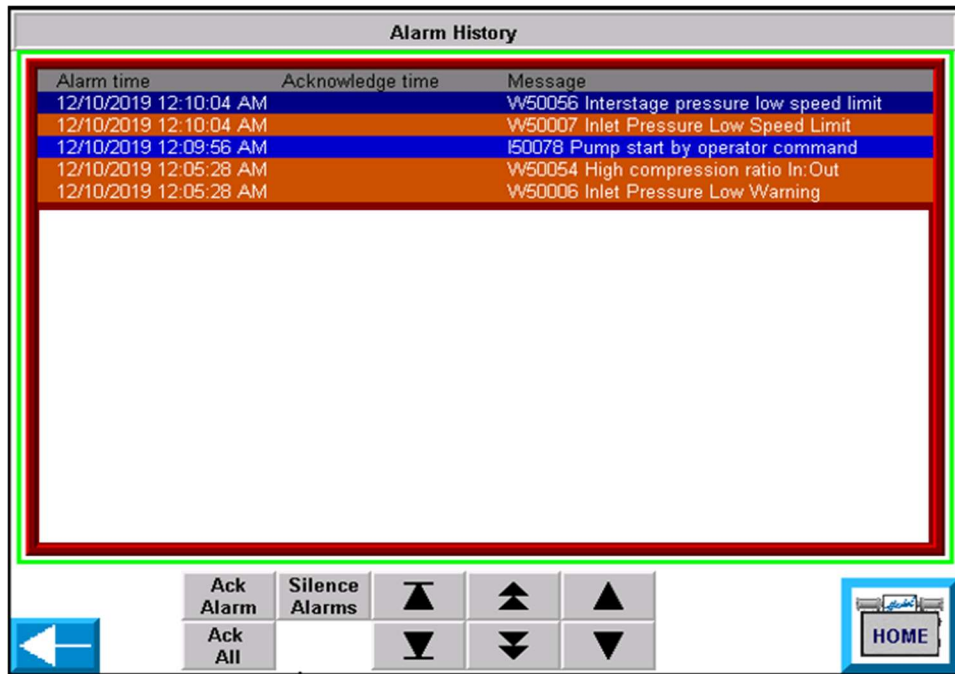

Alarm History screen

4. Use the up arrow and down arrow to select the alarm you resolved. Tap **Ack Alarm**.
5. To review the alarm history, use the up arrow and down arrow buttons to scroll through the alarms. You can also go to the first alarm and the last alarm in the history.

For a list of all alarms, see “List of Alarms”.

Troubleshooting

For actions, see “Inspection and Preventive Maintenance” and “About Service and Repair.”

Problem	Possible Cause	Action
Oil leak at shaft.	A seal on the rod is worn.	Replace the rod seal.
Oil leak at inlets.	A seal is extruding into the inlet port.	Replace the seal on the port.
The direction of oil flow is incorrect.	Motor phase is incorrect.	Shut down the system. In order to reverse the direction of the motor, 2 of the phases' positions in the facility 3phase supply cable need to be exchanged.
Booster does not build pressure.	External leakage is extreme.	Inspect the tubing, the end cap on each gas section, and the seals on the check valves.
	A seal failed on the gas section.	Inspect gas vent for leakage above 700 SCCM. If so, change piston seal.
	Faulty check valve.	Inspect the check valve for contaminants.
	Improper check valve.	Verify that the IN label on the body of check valve is matched with the IN label on the end cap of the gas section. Verify that OUT labels match.
Check valve is leaking.	Seal has contamination.	Repair check valve with the check valve seal kit.
	Seal is extruded.	
	Broken or worn spring in poppet valve.	
Gas leak at vents.	The seal on the gas piston is damaged.	Replace the seal on the gas piston.
Gas leaks externally	The seal on the gas barrel is damaged.	Service the gas section.
High outlet gas temperature.	Inlet pressure is decaying.	Adjust the inlet pressure to within recommended compression ratio.
	Pump speed is too high.	Decrease the CPM rate to slow the pump.
	Coolant flow is off or not adequate.	Inspect and service the cooling system.
Coolant leaks.	The seal on the cooling jacket of the gas barrel is damaged or worn.	Perform service on cooling system.

Inspection and Preventive Maintenance



WARNING: Use a lockout procedure for power and start controls.



CAUTION: Qualified electrical personnel must perform installation and maintenance. Before opening the electrical control cabinets, turn off and lock out the main isolating switch. Be aware that live parts might be present. Replace any removed covers before restarting the system.



CAUTION: Never change or defeat the function of electrical interlocks or other machine shutdown switches.



Hot Surfaces!

Inspection Schedule

Inspect the wear parts of the system according to the following table. After a period of steady production, revise the schedule according to your experience, but maintain a regular schedule. Use “Checklist for Inspection and Preventative Maintenance” to document the inspection.

Part	Action	Frequency
Gas Section: 1. Tie Rods 2. Adapter Piece	Torque Inspection	Every month.
Seals	Blowby Test	Every month.
Oil Level	Visual Inspection	Daily. Every time power turns on.

Checking the Surface and Connections

Before you power on the system:

- Inspect the external surfaces for dents, cracks, or missing parts.
- Check that the anchor bolts are tight.
- Check that all labels are present and legible.
- Check that connections are tight, straight, and not leaking.
- Check the torque on the screws for the both Gas Section's Tie Rods.

Running the Blow-By Test

You can test the condition of a seal in Pause condition.

1. Tap **Settings**, then **Operator Parameters**, and then **Press to Pause**. This pauses the pump but does not isolate the system from in-going or out-going process media.

2. Attach a flow meter to the Blow By port at the rear of the system. See “Attaching Air, Gas, and Coolant Lines.”
3. If the meter detects flow above 700 SCCM (cm³/min), plan to replace the piston seal set.
4. Remove the flow meter before starting the system.

Checking Oil

The motor housing has 2 sight glasses through which you can view the oil level. When the system is not running, you can see the oil level in both glasses.

If the oil level is not sufficient, add more oil. See “Adding New Oil.”

Disassembling the Gas Section

Tools:

- Hytorc® torque gun or any wrench with 200 ft-lbs (271 Nm).
- Krytox 240AZ lubricant



CAUTION: Do not allow any metal to touch the inner surface of the gas barrel. Any scratch can cause immediate leaks after re assembly. The barrel might need to be re honed.



Heavy Objects! Two Person lift required



Hot Surfaces! The tubes can be hot, allow to cool down before servicing.

1. Disconnect the tubing from the inlet and the outlet check valves.
2. Cap all the open ports to prevent contamination.
3. Loosen the Tie Rods on the Actuator, but do **not** remove. Use the same sequence as for tightening to loosen Tie Rods, but in increments of 100 ft-lbs (135 Nm).
4. Remove the Retainer Plate. Supporting the Retainer Plate is Gas Section leveling screw. Ensure to loosen the screws before removing the Gas Sections. When re-assembling Gas Sections, be sure to position leveling screw back to starting position. Typical to count and record rotations when loosening.
5. Loosen the Check Valves from the End Caps, but do not remove.
6. Remove the End Caps. Use a rubber Mallet if necessary.
7. To remove the Piston, insert the 10-32 screw into the Piston center-threaded hole and hand-tighten. Use the screw to pull the Piston out.
8. Never allow any hard metal material to touch the inner surface of the Gas Barrel. This can cause immediate leaks after reassembly. If Barrel is scratched, honing may have to be done.

You can now inspect, clean, and, if necessary, replace the components of the gas section.

Performing a Visual Inspection

Inspect the Barrel for scratches and changes in the polish. Burnishing discoloration is normal. For scratches deeper than fingernail depth, plan to replace the Barrel. Consult a Haskel representative for instructions.

Note: If the actuator requires service, you must return it to the factory. A replacement actuator is used while the original actuator is repaired.

Reassembling the Adapter Piece Assembly

1. Find the Adapter Piece Insert.



2. Find Wear Ring and roll the ring as shown and insert it into the Adapter Piece Insert ush Barrel against the Adapter Piece and hold in place.

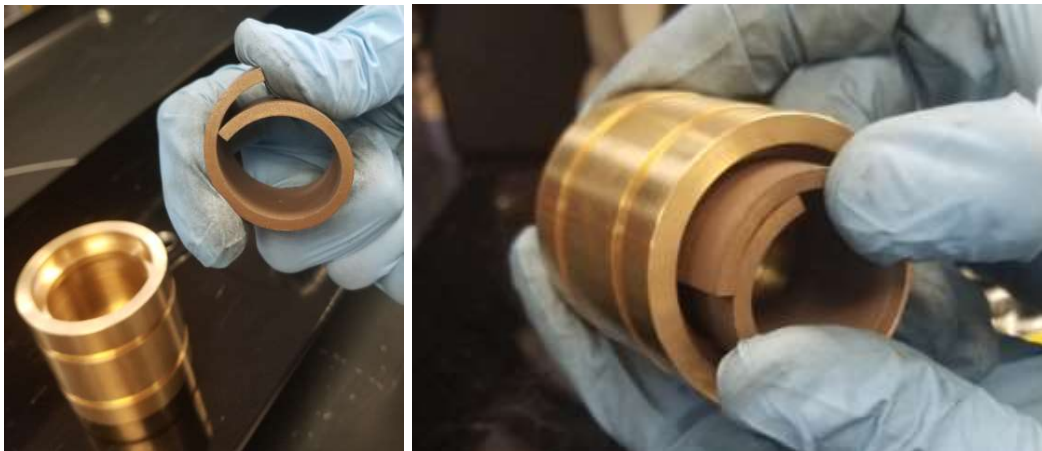

3. Install ring until edges are flush and ring is flat against internal diameter.

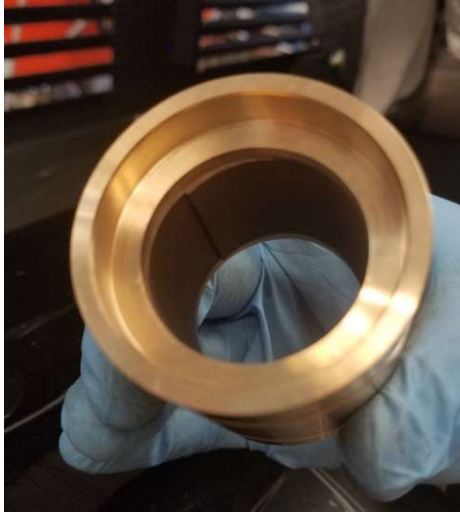

4. On edge with NO LIP, install gas compression seal with the spring facing outward. It should be flush upon final installation.



5. Turn over the Adapter Piece Insert and find the edge with a lip. Install the Wiper Seal with the steps facing outward.



6. Wiper seal should sit flush with edge as shown below.

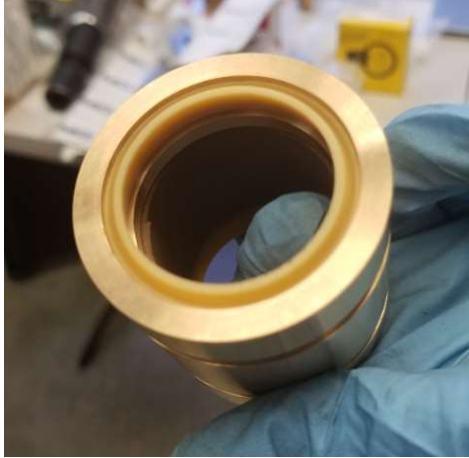

7. Coat O-Rings in versa lube and install on adapter piece insert. Then you may install Adapter Piece Insert into Adapter plate with gas compression seal facing upward



8. Use hammer and tool to install the Adapter Piece Insert so it is flush with internal surface (shown below).



9. Install Adapter Insert Cap. Align holes with adapter plate below.



10. Use pliers to hold hardware (screw and lock washer) and place a small amount of Loctite on end of screw. Place screws into internal holes and install them down with Allen key.



11. Place O-ring on shaft and install adapter plate onto shaft and press toward drive section of unit.

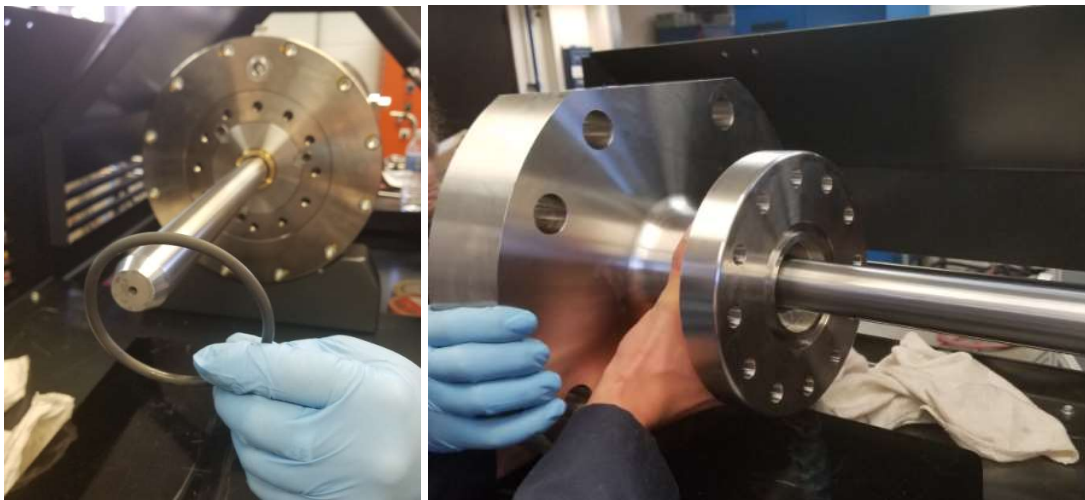

12. Insert O-ring into adapter plate, press until approximately 2 inches are left between the drive and adapter plate.

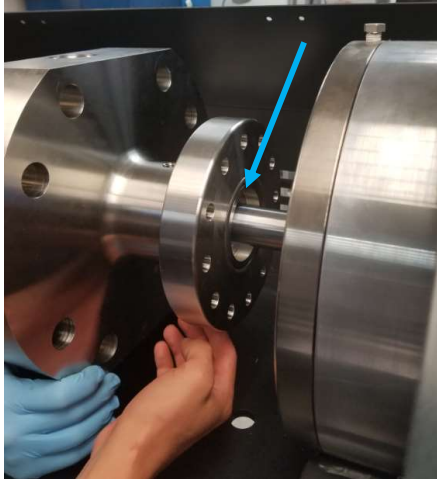

13. Obtain 12 bolts and lock washer and assemble as above. Place anti-seize on the end of the bolt. Install all screws into adapter plate and hand tighten.

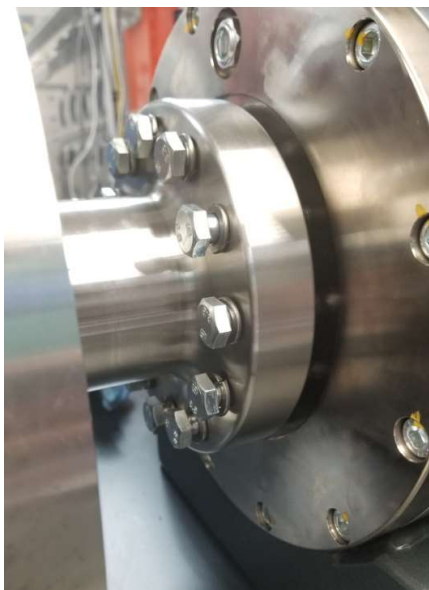

14. Insert screw from under panel so that end is visible on top side of panel. Turn screw into bolt until it is supporting adapter piece as shown below.

NOTE: One bolt will be shorter than the other due to heat exchanger interference

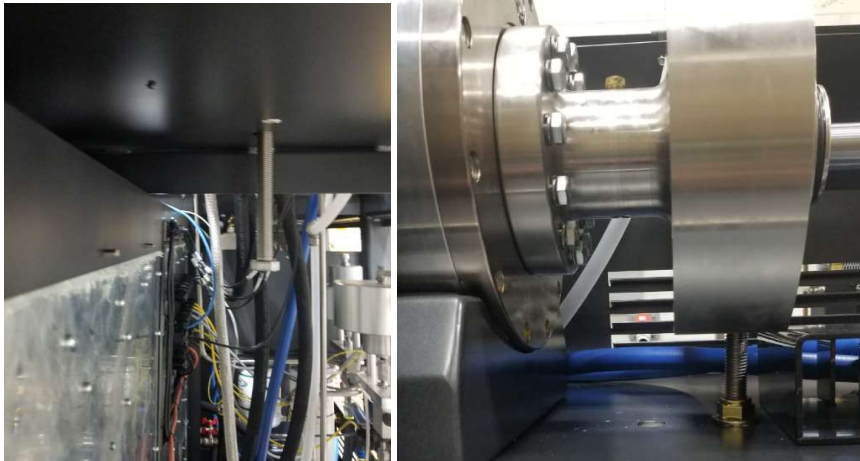

Reference Image (Prototype Unit)

15. Inspect Adapter Piece is aligned so that assembly maintains concentricity.



Reference Image (Prototype Unit)

16. Tighten bolts to 60 ft-lbs using a torque wrench so that adapter plate is fully installed.

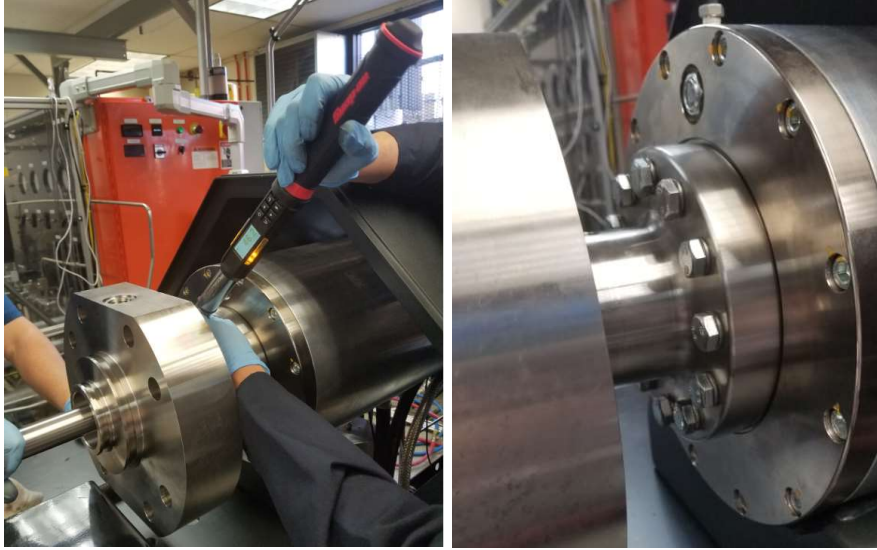

17. Use versa lube to coat O-ring and install on adapter plate.



Reassembling the Gas Section

1. Replace the O-ring for the End Cap. Apply a thin layer of Krytox 240AZ lubricant.
2. Push Barrel against the Adapter Piece and hold in place.
3. Install bore feature into the Gas Section.
4. Install the End Cap and the Check Valves. A small gap between the end cap and the cooling barrel is normal.
5. Install the Retainer Plate against the End Cap. Make sure the center bore of Retainer Plate matches the round, extruded feature on the End Cap to assure both parts are aligned.
6. Install washers. The grooved surface of the washers must face the retainer plate and the flat surface must face the nuts.
7. Tighten the nuts by hand.

8. Torque the tie rods to 200 ft lbs (271 Nm). Follow the tightening pattern on the label. Afterwards, be sure to position leveling screw back to starting position. Typical to count and record rotations when tightening. Use the recorded values from disassembling procedure.
9. Check all the flow directions on the check valves to identify the Inlet and Outlet Check Valves.
10. Check all connections to prepare to start.

Checklist for Inspection and Preventative Maintenance

Haskel Q Drive

Safety Inspection and Preventative Maintenance

Serial Number:

Performed By:

Date:

1. Inspection – Lockout Power! Risk of Electrical Shock!		Pass	Fail
1.1	External surfaces is free of damage and secure.		
1.2	Control panel is free of damage and legible.		
1.3	All labels are legible and secure.		
1.4	Power switch is functional and secure.		
1.5	Vents are free of damage and unobstructed.		
1.6	Connections are tight and straight.		
2. Gas Sections		Pass	Fail
2.1	Barrel		
2.2	Piston		
2.3	Piston seal		
2.4	Check Valves		
2.5	Tie Rods		
2.6	Leveling		
3. Servo Actuator		Pass	Fail
3.1	Oil level is visible.		

Comments

About Service and Repair

Select **Settings** and then **Service** to display the parameters and values for the system. The screen shows the time since the last service. Each Pressure Transducer (PT) and Thermocouple (TC) is identified by its serial number for calibration tracibility. The serial number and firmware version are located on the Settings screen and on the Service screen. In any service calls, include the model, serial number, and firmware version.

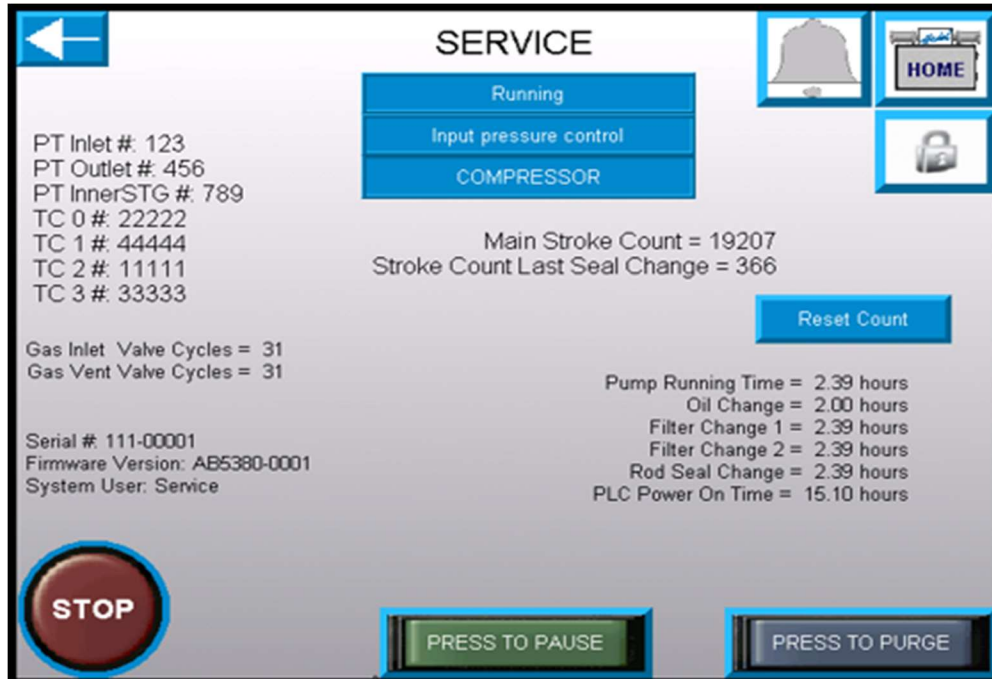

Service screen

The Service screen reports the current values for the parameters that control maintenance alarms.

Setting	Definition	Threshold
Main Stroke Count	Each push and return is 2 strokes, which is 1 cycle. This value cannot be reset.	18,000,000 at 30 CPM
Stroke Count Last Seal Change	When you replace a seal, tap Reset Count to restart the count at zero.	1,000 hours
Start Blow By Test	Tap PAUSE button to pause the pump but keep the valve open. A meter senses if any gas is in the valve, indicating a leak.	700 SCCM
Pump Running Time	Running time	10,000 hours
Lubricating Oil Change		2000 hours or 1 year
Moisture Absorption Fiilter Change		1000 hours or 6 months
Rod Seal Change		2000 hours
Gas Inlet Valve Cycles	Valves open when the system is powered on and close when it is powered off. One cycle is a valve opening and closing	2,000,000 cycles
Gas Outlet Valve Cycles		

When you exceed these limits, an alarm reminds you. The alarms create a maintenance record. Maintain the system to maintain the warranty. Replace parts according to the following schedule.

Replacing Part	Frequency
Tie Rods	Every 3 years.
Gas Barrels	Every 7 years
Check Valves	After 2,000,000 cycles
Gas Section Seals	After 1000 hours
Oil Filter	After 2000 hours or 1 year
Oil	After 2000 hours

After you complete the service, log into the system using a Service account and reset the values to zero.

Ordering Replacement Parts

A good practice is to stock replacement parts to avoid interruption of production. When ordering, specify the serial number of the system and the item number of the part.

Item	Part
88338	Tie Rods
88226	150mm Gas Barrel
88224	90mm Gas Barrel
88221	63mm Gas Barrel
88321	Seal Kit for 150 mm Piston Assembly
88322	Seal Kit for 90 mm Piston Assembly
88323	Seal Kit for 63 mm Piston Assembly
88289	Seal Kit for Check valve for inlet
88289	Seal Kit for Check valve for outlet
88450	Servo Actuator Repair Kit
88449	Seal Kit for 150 mm Gas Section (includes Piston As. Seal Kit)
88448	Seal Kit for 90 mm Gas Section (includes Piston As. Seal Kit)
88447	Seal Kit for 63 mm Gas Section (includes Piston As. Seal Kit)



WARNING: Do not modify the equipment or replace a part with a non-factory part. Modifying the equipment may cause unpredictable operation which may result in injury to the operator. Modifying this equipment voids the warranty.

Replacement Procedures



WARNING: Use a lockout procedure for power and start controls.



CAUTION: Only trained and authorized personnel can service the machine. Before servicing, follow your site's approved lock-out procedures.



CAUTION: Never change or defeat the function of electrical interlocks or other machine shutdown switches.

- Replacing Cooling Jackets
 - Replacing the Piston Seals
1. Replacing Oil Filter and OilWipe away any spills and check for oil leaks.
 2. Go to the Service page and tap **Reset Count** to restart the count at zero.

Re-Assembling Drive Rod Assembly

Tools:

- Gland Wrench and Spanner
 - Test and transport plate
 - Loctite 7471
 - Loctite 243
 - FML-2 Lubricant
1. Install End Cap Insert, Seal Housing, and Guide Bush into the End Cap. At this point O-rings and seals don't need to be installed as they are just used to home the Actuator. Gland Wrench and Spanner.
 2. Assemble the test and transport plate to seat seal housing. Assemble using 6/off M12x1.25x35 SHCS.

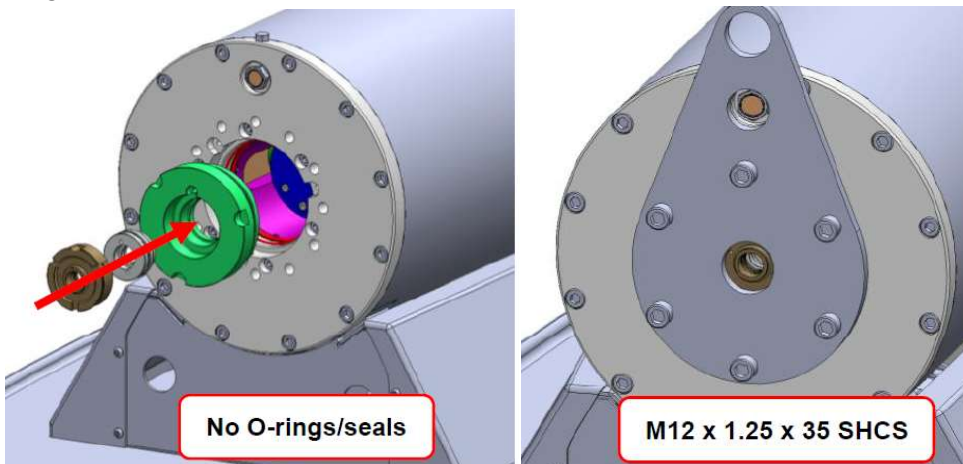

3. Remove the End Cap Insert, Seal Housing, and Guide Bush. Use proper Wrench to remove the Seal Housing.

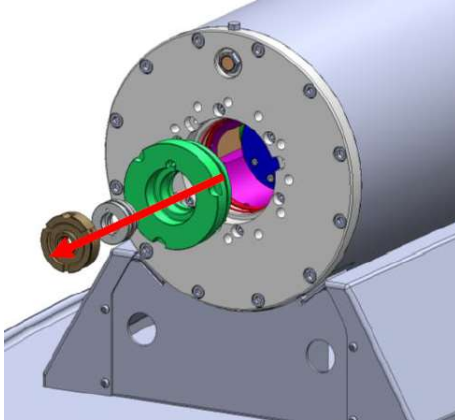

4. Remove the plunger retainer plate by removing the 8/off M5x16 SHCS fasteners.

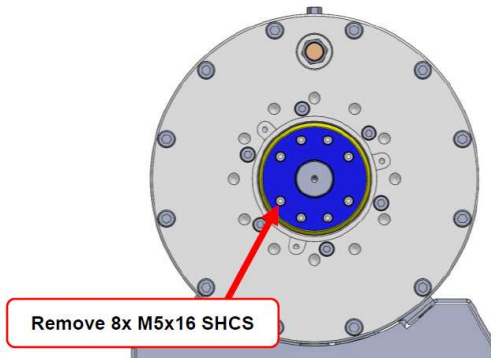

5. Re-assemble the plunger retainer and Drive Rod using 8/off M5x16 SHCS Black. Use Loctite 7471 activator and Loctite 243 thread locker on each fastener. Open the inlet valve: **DO NOT DROP ANYTHING (SCREWS OR FOD) IN THE ACTUATOR!** Torque each M5 screw to 9.5Nm or 7ft•lbs and paint mark, and insert BS154 O-ring to the End Cap Insert using FML-2.

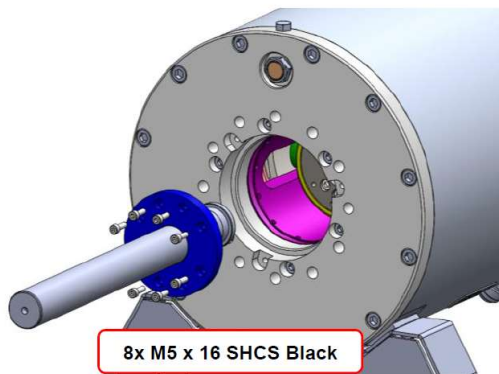

6. Assemble the clamps with 3/off M6x12 SHCS Black. Use Loctite 7471 and 243. Torque each M6 to 16Nm. Paint mark SHCS after tightening.

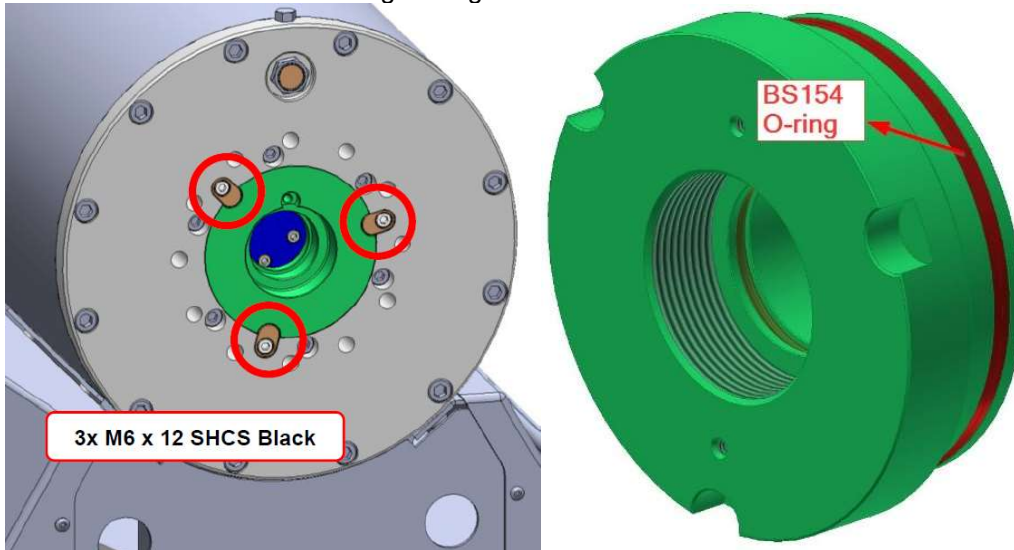

- Replacing the Tie Rods
- Replacing Check Valves
- Replacing Cooling Jackets

Replacing the Piston Seals

The piston seal package includes seals and PTFE-based bearings.

1. Perform the procedure in “Disassembling the Gas Section.”
2. Insert the 10-32 screw into the piston center threaded hole and hand tighten. Use the screw to pull the piston out.
3. Inspect the barrel for scratches and changes in the polish. Burnishing discoloration is normal. For scratches deeper than fingernail depth, plan to replace the barrel. Consult a Haskel representative for instructions.
4. Remove the snap ring from the piston body.
5. Remove the front bearing, piston seal, and backup. Make a note of the orientation of the piston seal.
6. Open the new seal kit.
7. Install the backup, the piston seal, and the front bearing. Position the piston seal in its original orientation.
8. Replace the snap ring.
9. Position the piston so that its flat surface is facing the end cap.
10. Push the piston into the barrel to a depth of about 0.75 in (20 mm) or until it touches the rod. Use a rubber mallet if necessary.
11. Continue to reassemble the gas section from Step 4 of “Reassembling the Gas Section.”

12. Go to the Service page and tap **Reset Count** to restart the count at zero.

Replacing Oil Filter and Oil

The lubricating oil capacity is 30 litres (8 gallons). Replacement lubricating oil: 20 litres (5.2 gallons), Syn-Gear EP150. Replace the oil filters each time you replace the oil.

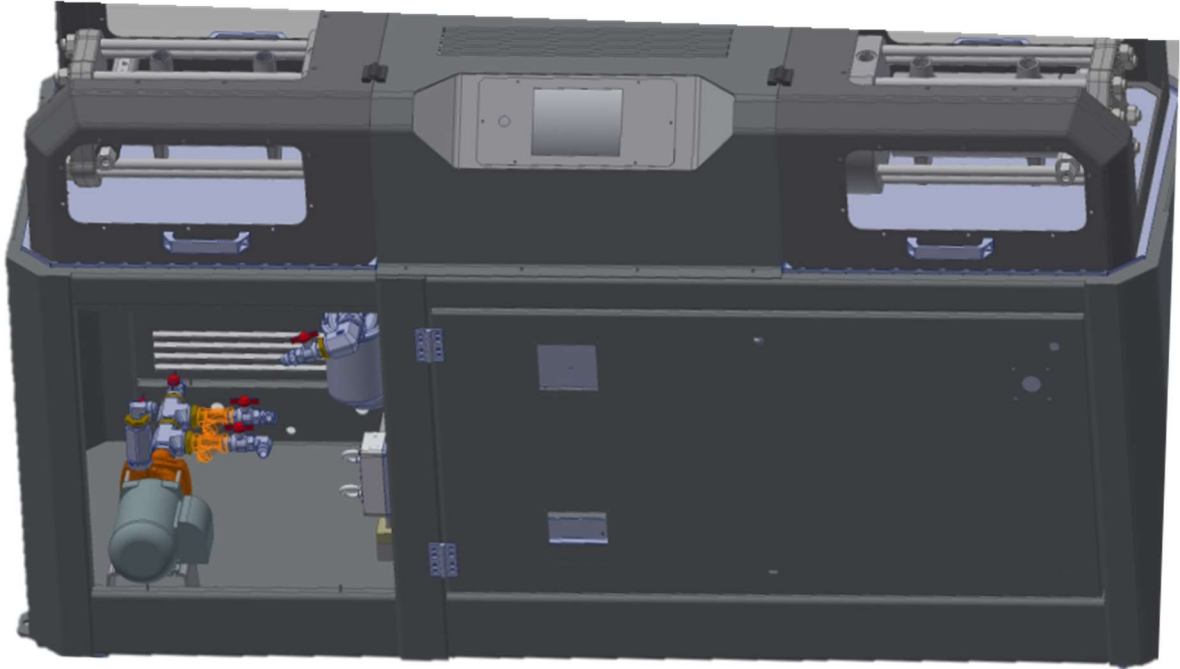

Oil Pump Assembly in the Production unit

Tools:

- 31 litre (8.2 gallons) container in total.
 - Container for approximately 1 litre (34 oz.)
 - Container for approximately 30 litres (8 gallons)
- Strap wrench
- 12 mm hoses (2)
- Hand pump

Removing the Oil Filters

1. Place the small container under the oil filters to catch any drips.
2. Remove the two 1/8 in breather plugs on the top of the motor end caps.
3. Close the drain valve.
4. Remove the plug.
5. Place the large container under the drain valve or attach a hose from the valve to the container.

6. Open the drain valve.
7. Wait at least 15-30 minutes for the oil to drain.
8. Remove each oil filter using a strap wrench. The filter thread is a standard right-hand thread. If you must remove the oil filters while there is still oil in the pump, turn all valves to the off position. Place a small container approximately 1 litre (34 oz.) underneath the filter.
9. Close the drain valve and replace the plug.

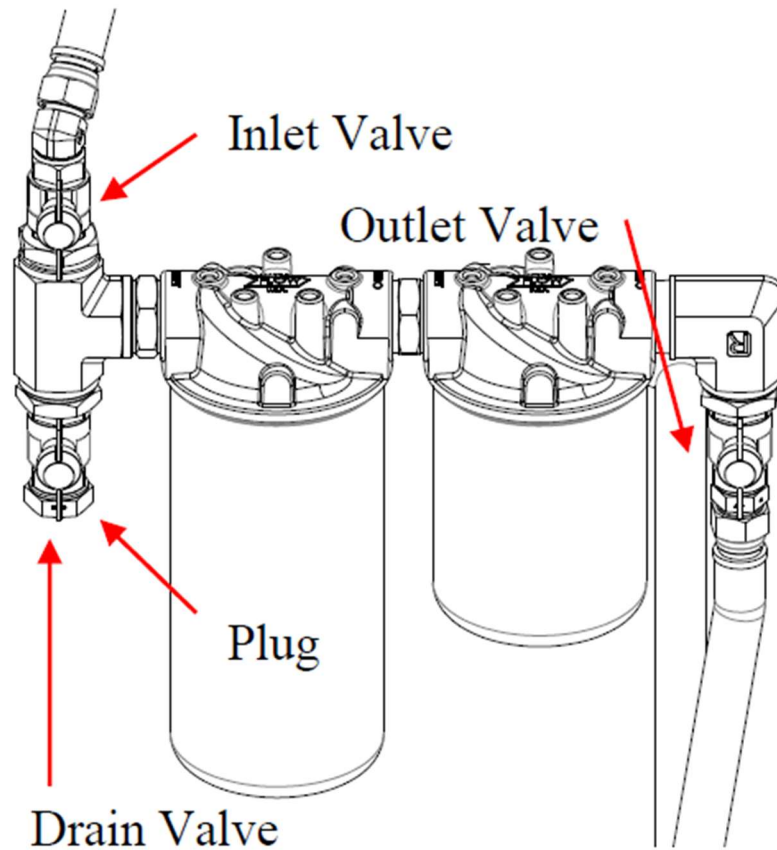

Components of Oil Circulation

Installing New Oil Filters

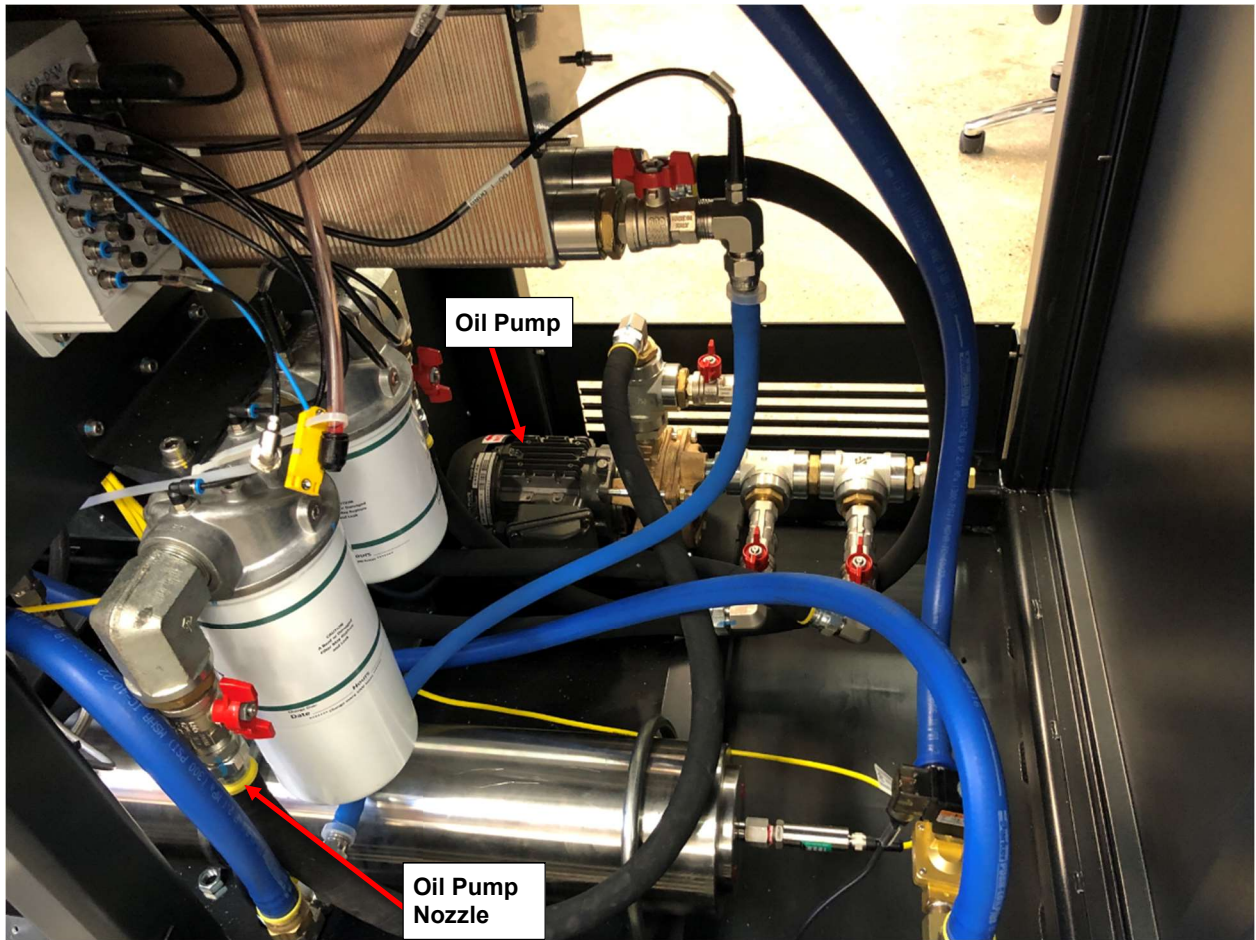

Oil Circulation (Reference Image from Q-Drive's Prototype)

1. Pour some oil directly into the new filter.
2. Spread a small amount of oil on the face of the rubber seals.
3. Tighten each oil filter until the seal touches the sealing face.
4. Tighten another $\frac{3}{4}$ of a turn by hand.

Draining Oil from Actuator

1. In order to drain oil, remove $\frac{3}{4}$ " BSP plug from the Oil Pump and attach a hose.

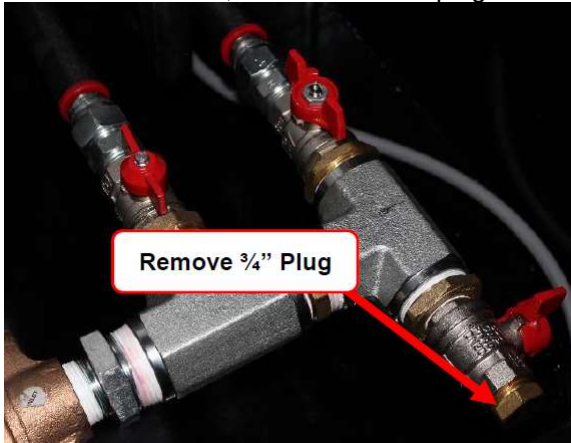

2. Place ball valves shown below in the required open or closed position

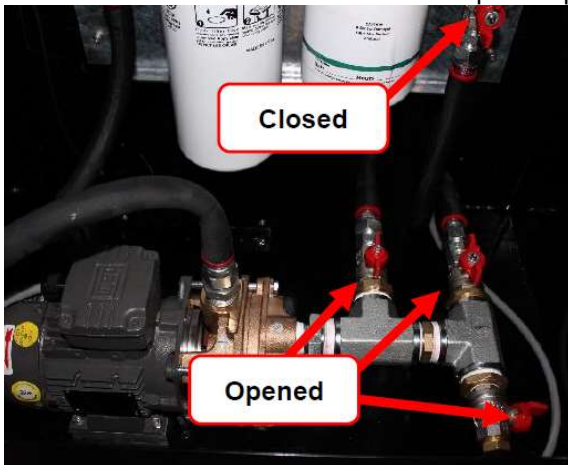

3. Locate both $\frac{1}{8}$ " hex Breather Plugs on the top of each Actuator's End Cap and remove them.

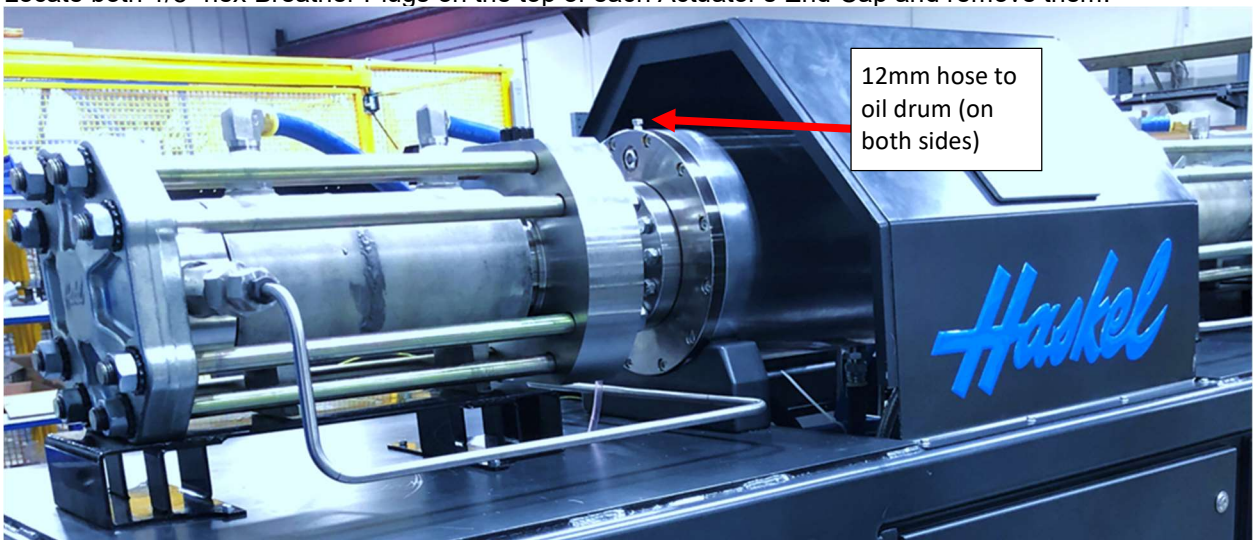

Q-Drive Prototype (Reference Image)

Adding New Oil

3. From empty, the actuator holds approx. 33L of oil.
4. Remove the $\frac{3}{4}$ " BSP plug from the oil pump and attach a hose.

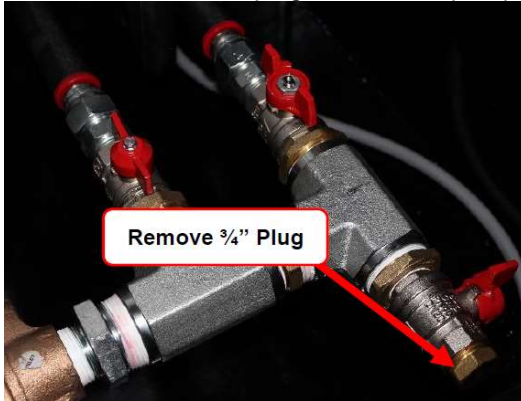

5. Run hose to container full of oil. The oil pump will be used to help fill actuator with oil.

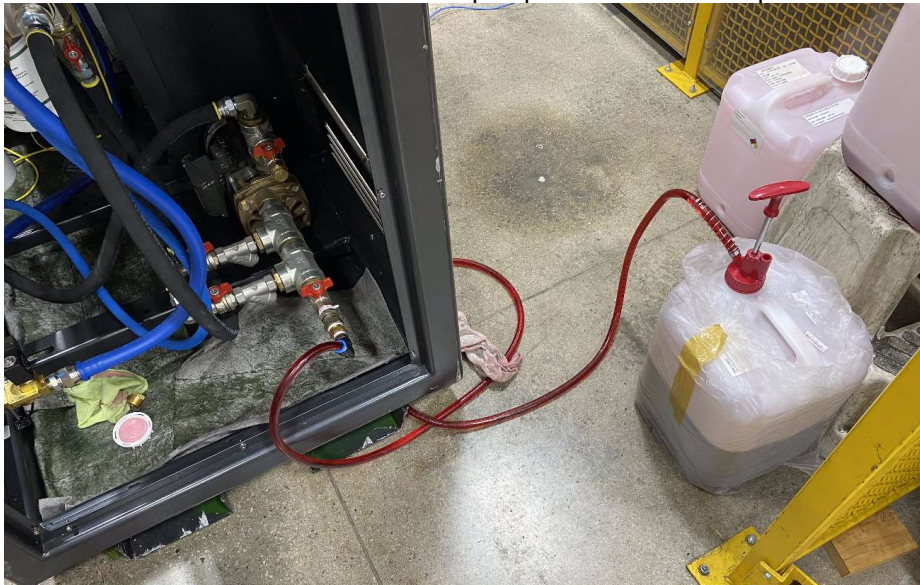

6. Open/Close ball valves based on images above to allow oil flow.

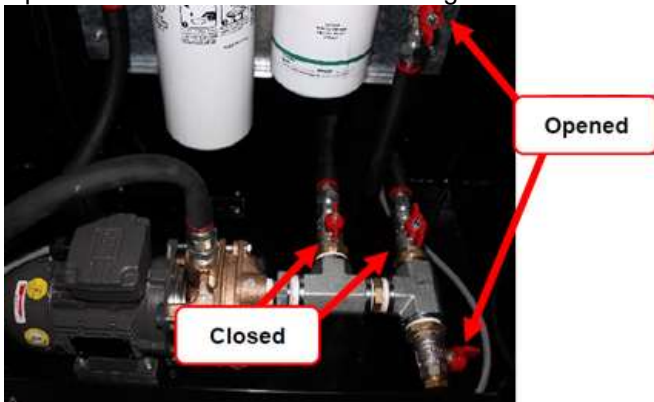

7. Loosen the Breather Plug and start hand pumping the oil. Keep observing the sight through glasses which you can view the oil level on Actuator.



8. The system will hold approx. 33L of oil. When the system is full of oil there will be an uninterrupted flow of oil. Wipe away any spills and check for oil leaks.
9. Go to the Service page and tap **Reset Count** to restart the count at zero.

Re-Assembling Drive Rod Assembly

Tools:

- Gland Wrench and Spanner
 - Test and transport plate
 - Loctite 7471
 - Loctite 243
 - FML-2 Lubricant
7. Install End Cap Insert, Seal Housing, and Guide Bush into the End Cap. At this point O-rings and seals don't need to be installed as they are just used to home the Actuator. Gland Wrench and Spanner.

8. Assemble the test and transport plate to seal housing. Assemble using 6/off M12x1.25x35 SHCS.

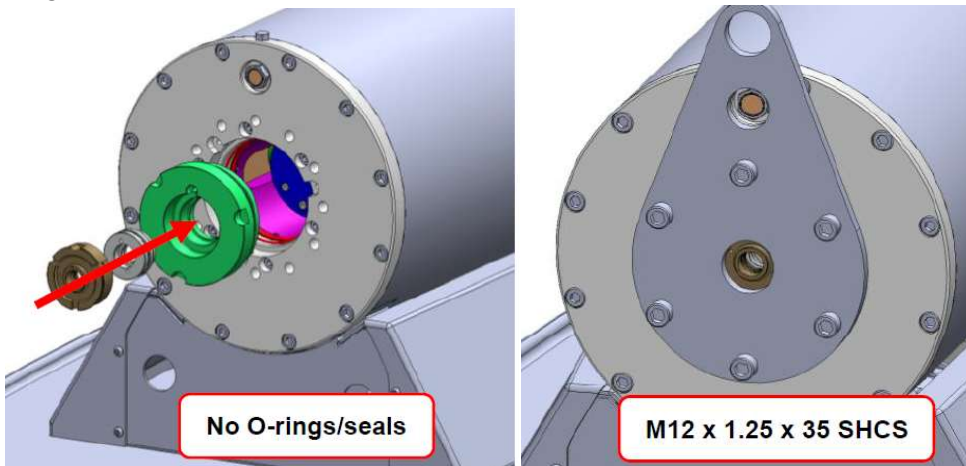

9. Remove the End Cap Insert, Seal Housing, and Guide Bush. Use proper Wrench to remove the Seal Housing.

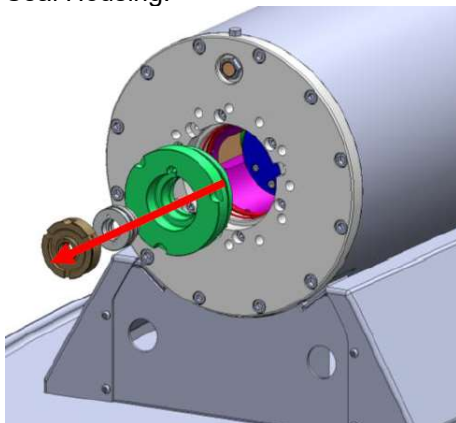

10. Remove the plunger retainer plate by removing the 8/off M5x16 SHCS fasteners.

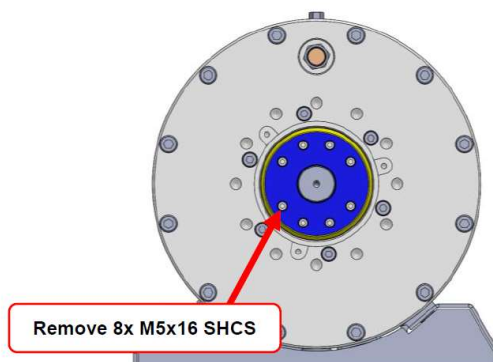

11. Re-assemble the plunger retainer and Drive Rod using 8/off M5x16 SHCS Black. Use Loctite 7471 activator and Loctite 243 thread locker on each fastener. Open the inlet valve: **DO NOT DROP ANYTHING (SCREWS OR FOD) IN THE ACTUATOR!** Torque each M5 screw to 9.5Nm or 7ft•lbs

and paint mark, and insert BS154 O-ring to the End Cap Insert using FML-2.

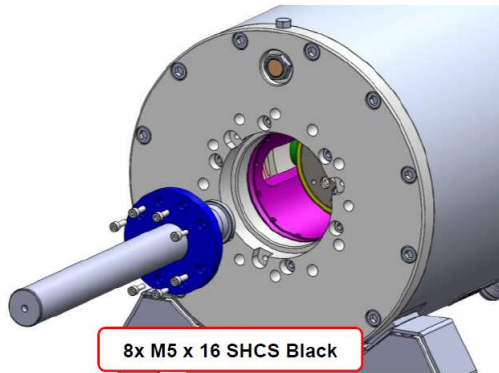

12. Assemble the clamps with 3/off M6x12 SHCS Black. Use Loctite 7471 and 243. Torque each M6 to 16Nm. Paint mark SHCS after tightening.

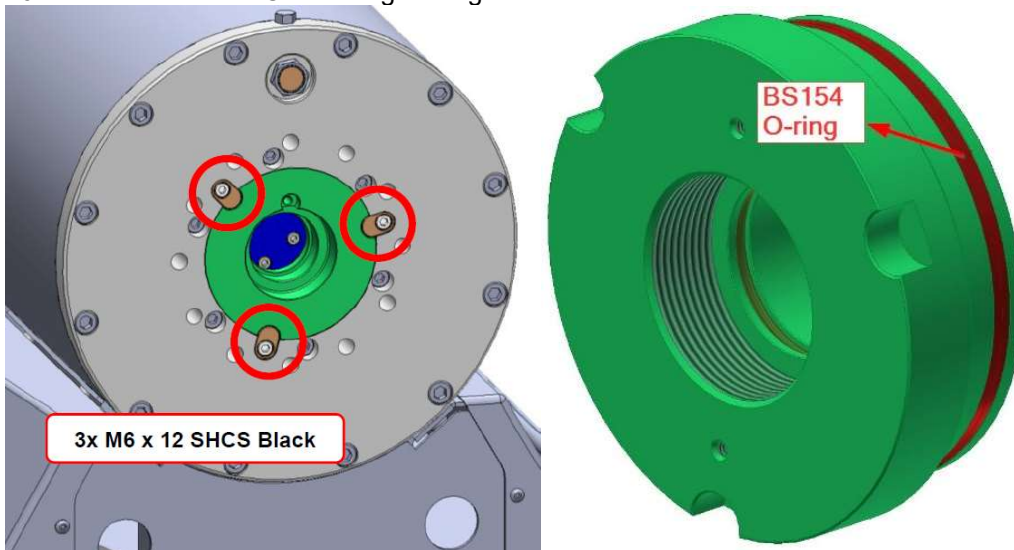

Replacing the Tie Rods

Tools:

- Hytorc® torque gun or any wrench with 200 ft-lbs (271 Nm)

If you perform this procedure in addition to other service procedures, disassemble the gas section. If you perform only this procedure, it is not necessary to disassemble the gas section.

1. Disassemble the gas section or loosen each tie rod according to the tightening sequence until each tie rod reaches 200 fts-lb (271 N-m).
2. Each tie rod screws into the end cap. Unscrew one tie rod. Set aside the tie rod, washers, and nuts. Do not reuse them.
3. Insert the new tie rod and screw into the Retainer Plate by hand.
4. Install the washer with the flat side facing outward.
5. Install the nut and screw by hand, leaving about 2 threads.

6. After you replace the last tie rod, tighten each nut by hand.
7. Using the tightening sequence, torque each nut on the end cap side.
8. Check the torque on the drive side; 200 ft-lbs (271 Nm).

Replacing Check Valves

To replace a check valve, replace the entire check valve assembly.

Pay attention to the existing inlet and outlet ports.

1. Use an adjustable wrench to loosen the check valve.
2. Remove the check valve.
3. Open the replacement kit for check valves. Locate the IN check valve.
4. Install the IN check valve so that it connects to the IN end cap.
5. Install the OUT check valve so that it connects to the OUT end cap.
6. Tighten the assemblies. Apply torque of 50 ± 5 ft-lbs (68 ± 7 Nm)

Replacing Cooling Jacket



1. Disconnect the tubing or pipes from the inlets and from the outlets.
2. Cap all the open ports to prevent contamination.
3. Loosen the Tie Rods on the Gas Sections but do not remove. Refer to the tightening sequence. Use the same sequence to loosen, but in increments of 100 ft-lbs (135 Nm).
4. Loosen the Check Valves from the End Caps but do not remove.
5. Remove the End Caps. Use a rubber mallet if necessary.
6. Inspect the barrel for scratches and changes in the polish. Burnishing discoloration is normal. For scratches deeper than fingernail depth, plan to replace the barrel. Consult a Haskel representative for instructions.
7. Remove the Barrel.
8. Remove the Cooling Jacket from the Adapter Piece. Save the O-ring from the adapter.
9. Set aside the barrel assembly and cover it until you reassemble.
10. Remove the snap ring.
11. Pull out the barrel from the jacket.
12. Inspect the O-rings for the barrel. Plan to replace them if necessary.
13. Apply a thin layer of all-purpose grease to the O-rings housed in the grooves.
14. Clean and lubricate the O-ring with all-purpose grease.
15. Attach the site's coolant line to the system's coolant inline port.
16. Insert Barrel assembly to the Adapter Piece.
17. Reassemble the Gas Section, according to "Reassembling the Gas Section."

Points of Connections

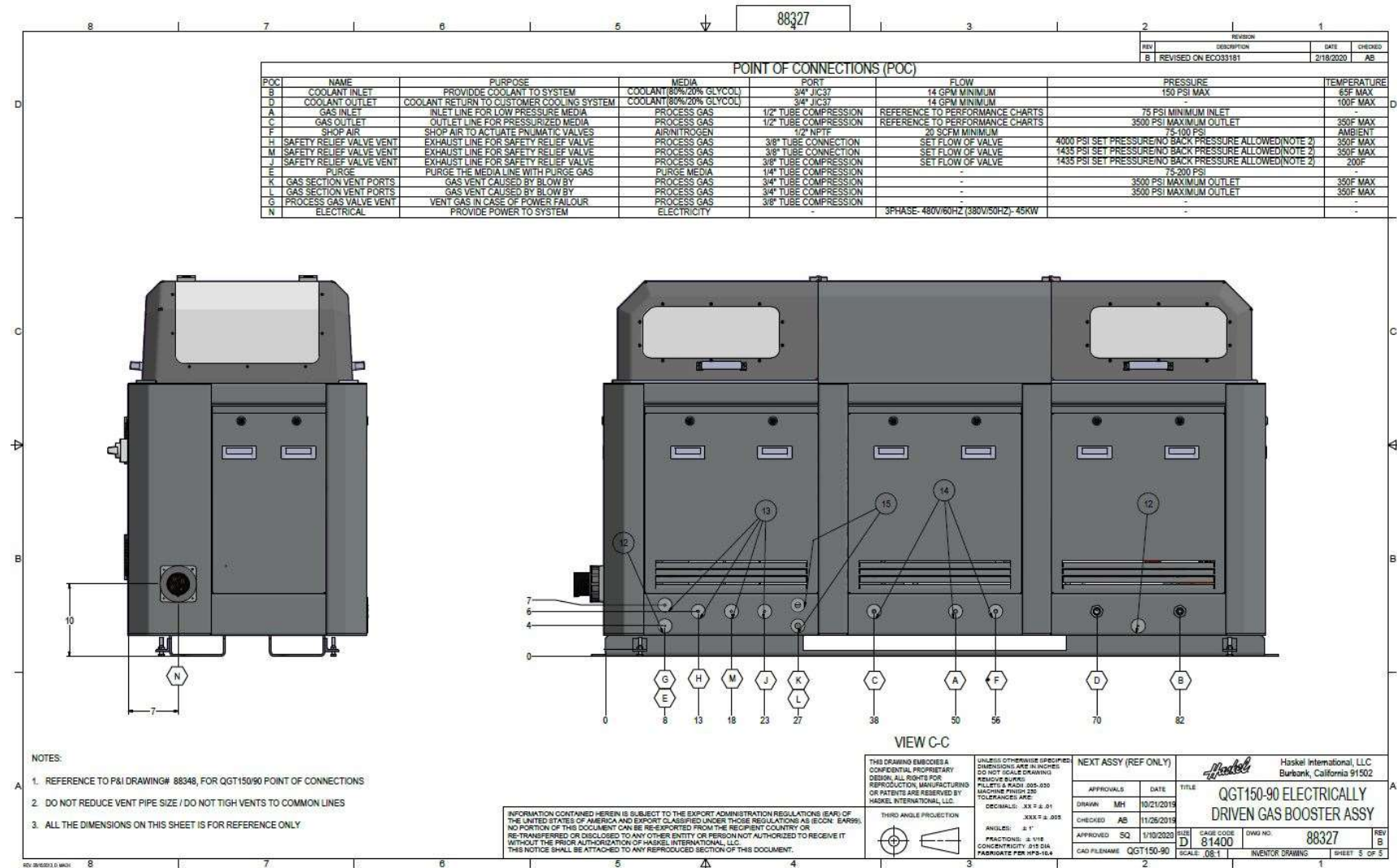

Q-Drive Installation, Operation, and Maintenance Manual

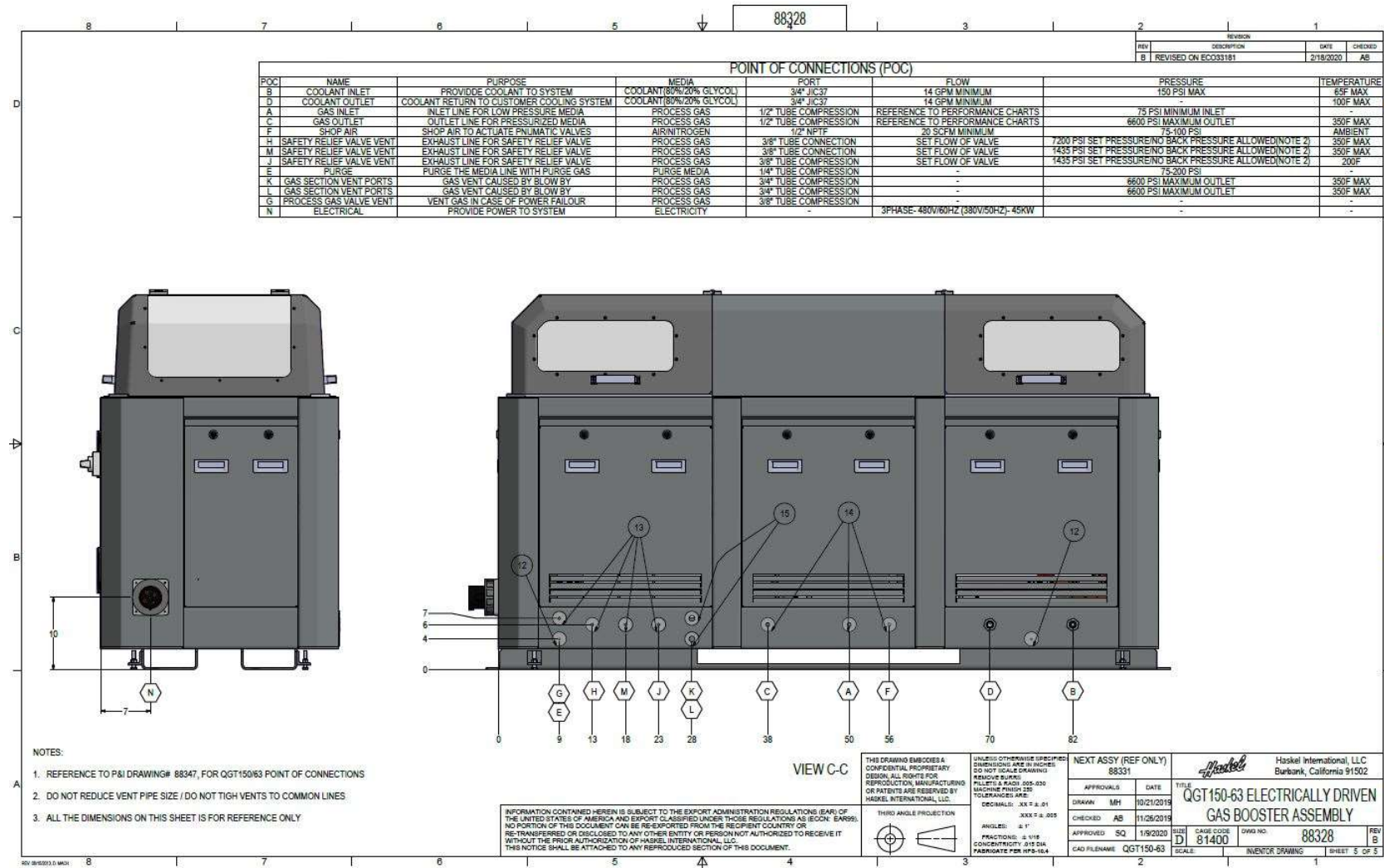

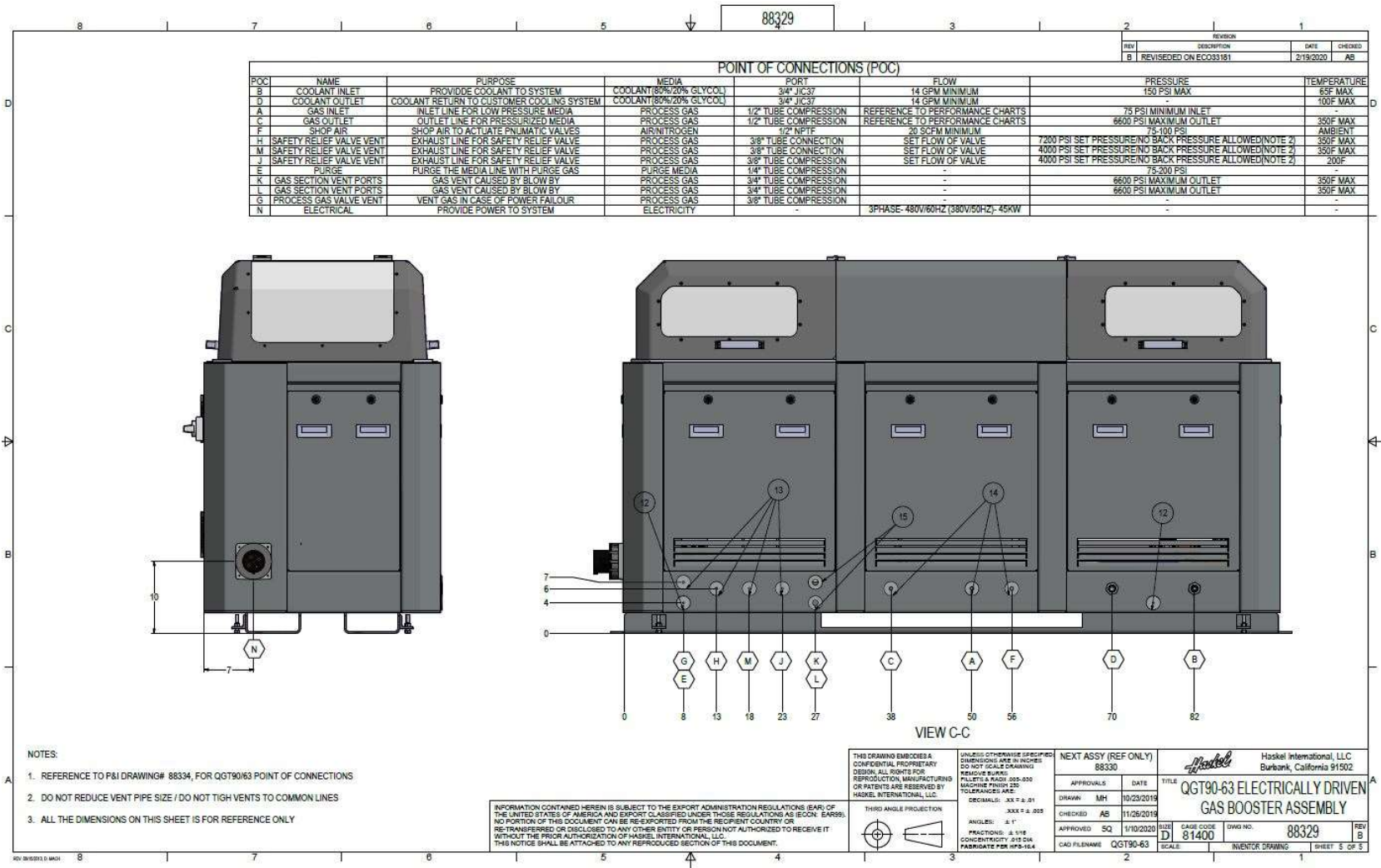

Q-Drive Installation, Operation, and Maintenance Manual

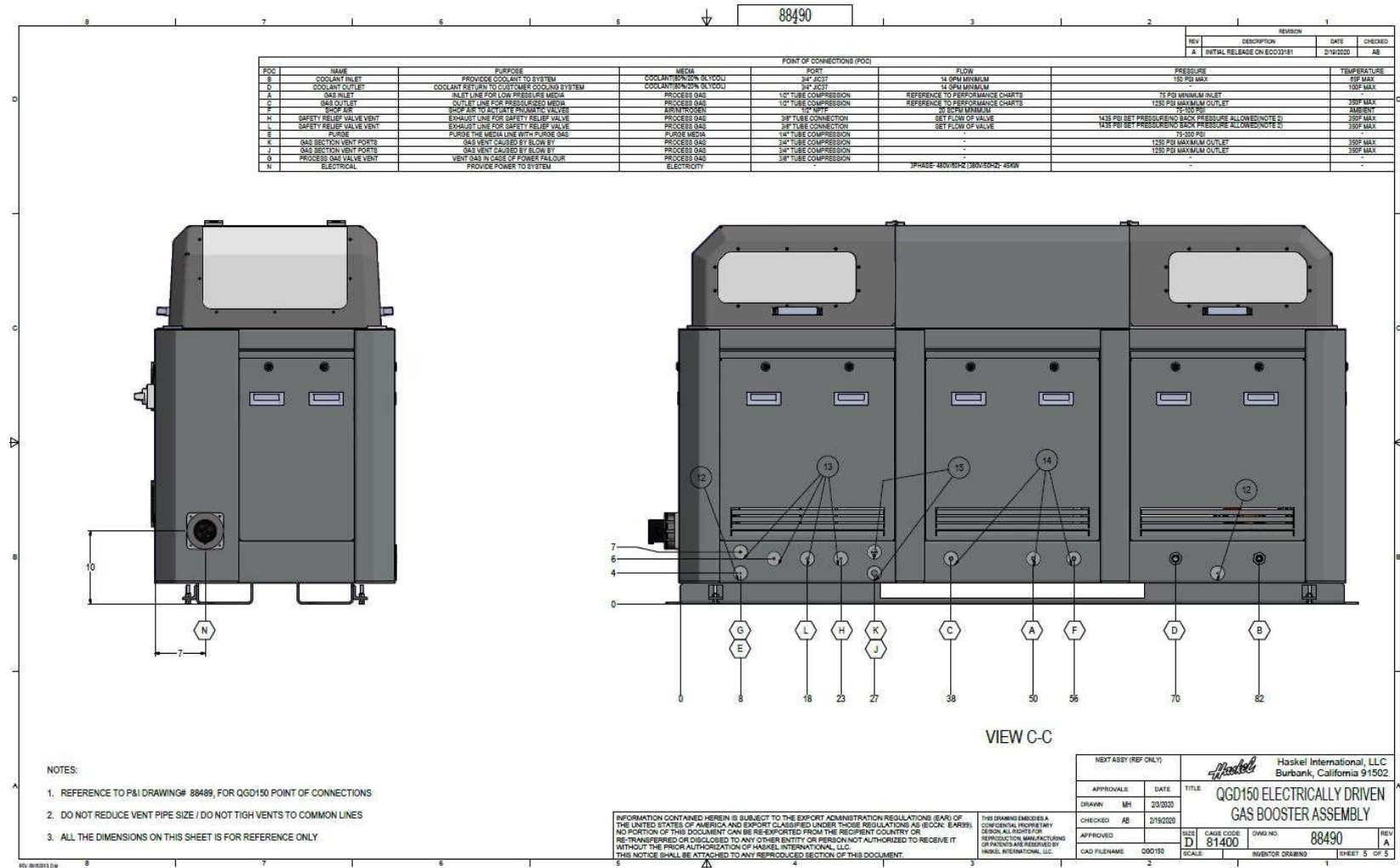

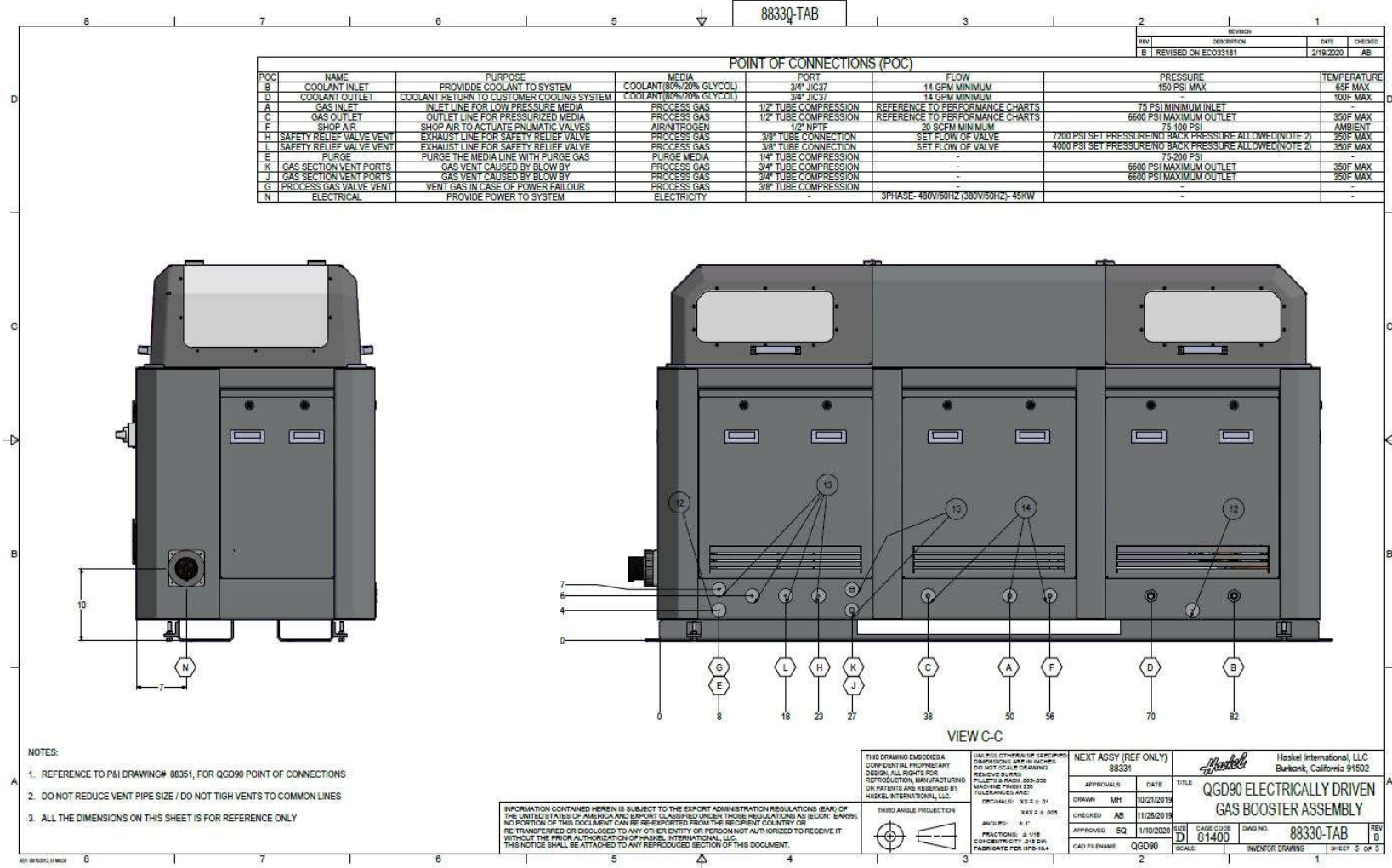

Q-Drive Installation, Operation, and Maintenance Manual

88331

REV	DESCRIPTION	DATE	CHECKED
B	REVISED ON ECO33181	2/19/2020	AB

POC	NAME	PURPOSE	MEDIA	PORT	FLOW	PRESSURE	TEMPERATURE
B	COOLANT INLET	PROVIDE COOLANT TO SYSTEM	COOLANT(80%/20% GLYCOL)	3/4" JIC37	14 GPM MINIMUM	150 PSI MAX	55F MAX
D	COOLANT OUTLET	COOLANT RETURN TO CUSTOMER COOLING SYSTEM	COOLANT(80%/20% GLYCOL)	3/4" JIC37	14 GPM MINIMUM	-	100F MAX
A	GAS INLET	INLET LINE FOR LOW PRESSURIZED MEDIA	PROCESS GAS	1/2" TUBE COMPRESSION	REFERENCE TO PERFORMANCE CHARTS	75 PSI MINIMUM INLET	-
C	GAS OUTLET	OUTLET LINE FOR PRESSURIZED MEDIA	PROCESS GAS	1/2" TUBE COMPRESSION	REFERENCE TO PERFORMANCE CHARTS	6600 PSI MAXIMUM OUTLET	350F MAX
F	SHOP AIR	SHOP AIR TO ACTUATE PNEUMATIC VALVES	AIR/NITROGEN	1/2" NPTF	20 SCFM MINIMUM	75-100 PSI	AMBIENT
H	SAFETY RELIEF VALVE VENT	EXHAUST LINE FOR SAFETY RELIEF VALVE	PROCESS GAS	3/8" TUBE CONNECTION	SET FLOW OF VALVE	7200 PSI SET PRESSURE/NO BACK PRESSURE ALLOWED(NOTE 2)	350F MAX
L	SAFETY RELIEF VALVE VENT	EXHAUST LINE FOR SAFETY RELIEF VALVE	PROCESS GAS	3/8" TUBE CONNECTION	SET FLOW OF VALVE	7200 PSI SET PRESSURE/NO BACK PRESSURE ALLOWED(NOTE 2)	350F MAX
E	PURGE	PURGE THE MEDIA LINE WITH PURGE GAS	PURGE MEDIA	1/4" TUBE COMPRESSION	-	75-200 PSI	-
K	GAS SECTION VENT PORTS	GAS VENT CAUSED BY SLOW BY	PROCESS GAS	3/4" TUBE COMPRESSION	-	6600 PSI MAXIMUM OUTLET	350F MAX
J	GAS SECTION VENT PORTS	GAS VENT CAUSED BY SLOW BY	PROCESS GAS	3/4" TUBE COMPRESSION	-	6600 PSI MAXIMUM OUTLET	350F MAX
G	PROCESS GAS VALVE VENT	VENT GAS IN CASE OF POWER FAILOUR	PROCESS GAS	3/8" TUBE COMPRESSION	-	-	-
N	ELECTRICAL	PROVIDE POWER TO SYSTEM	ELECTRICITY	-	3PHASE-480V/60HZ (380V/50HZ)-45KW	-	-

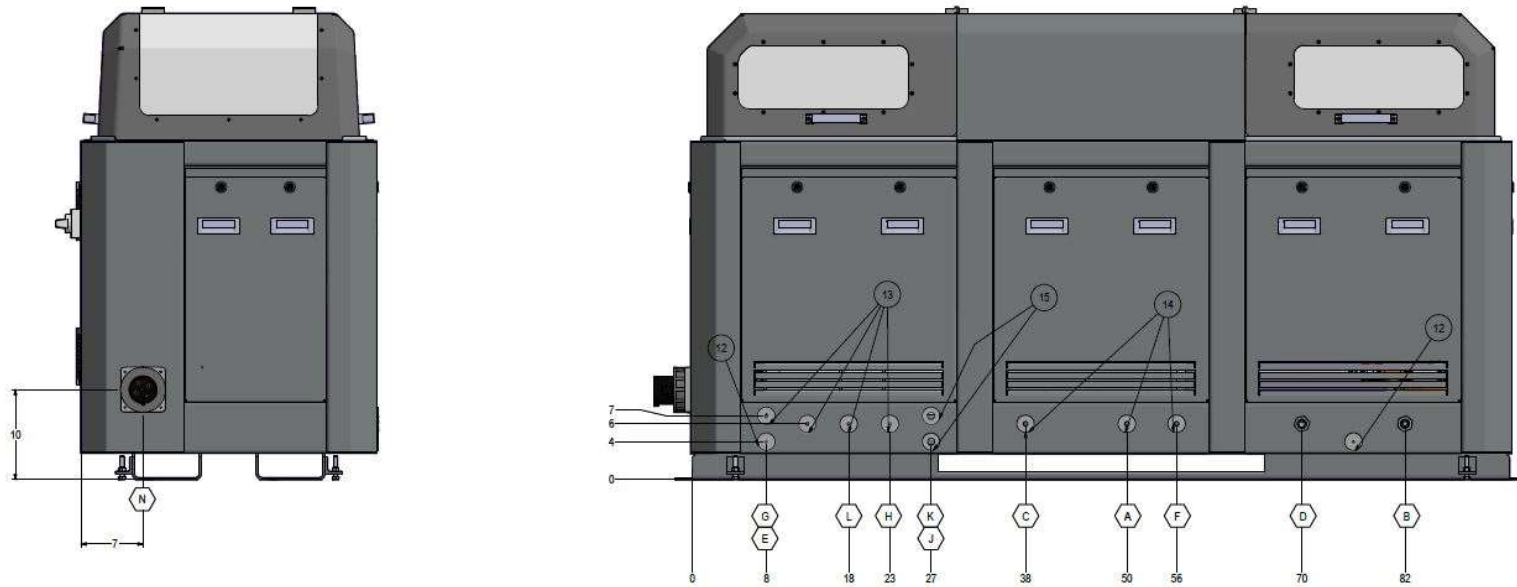

NOTES:

1. REFERENCE TO P&I DRAWING# 88349, FOR QGD63 POINT OF CONNECTIONS
2. DO NOT REDUCE VENT PIPE SIZE / DO NOT TIGH VENTS TO COMMON LINES
3. ALL THE DIMENSIONS ON THIS SHEET IS FOR REFERENCE ONLY

INFORMATION CONTAINED HEREIN IS SUBJECT TO THE EXPORT ADMINISTRATION REGULATIONS (EAR) OF THE UNITED STATES OF AMERICA AND EXPORT CLASSIFIED UNDER THOSE REGULATIONS AS (EARS). NO PORTION OF THIS DOCUMENT CAN BE RE-EXPORTED FROM THE RECEIPT COUNTRY OR RE-TRANSFERRED OR DISCLOSED TO ANY OTHER ENTITY OR PERSON NOT AUTHORIZED TO RECEIVE IT WITHOUT THE PRIOR AUTHORIZATION OF HASKEL INTERNATIONAL, LLC. THIS NOTICE SHALL BE ATTACHED TO ANY REPRODUCED SECTION OF THIS DOCUMENT.

THIS DRAWING EMBODIES A CONFIDENTIAL PROPRIETARY DESIGN. ALL RIGHTS FOR REPRODUCTION, MANUFACTURING OR PATENTS ARE RESERVED BY HASKEL INTERNATIONAL, LLC. THIRD ANGLE PROJECTION 	UNLESS OTHERWISE SPECIFIED DIMENSIONS ARE IN INCHES DO NOT SCALE DRAWING REMOVE SURF FINISHES UNLESS SPECIFIED MACHINE FINISH 250 TOLERANCES ARE DECIMALS: .XX ± 0.01 .XXX ± 0.005 ANGLE: ± 1° FINISHES: @ 1/16 CONCENTRICITY .015 DIA FABRICATE PER NPS-164	NEXT ASSY (REF ONLY) 88330	Haskel International, LLC Burbank, California 91502
		APPROVALS DRAWN MH 10/21/2019 CHECKED AB 11/26/2019 APPROVED SQ 3/10/2020 CAD FILENAME QGD63	DATE 10/21/2019 11/26/2019 3/10/2020
		DWG NO. 88331	REV B

List of Alarms

Errors

Errors	AlarmCode
Actuator Parking Failed - Actuator Off	50001
Actuator Parking Failed - Timeout	50002
Actuator Parking Error - Actuator off while holding	50003
Serial link PLC to ESPCM is down	50004
Actuator has reported an error state	50005
Inlet Pressure High Error	50009
Input Pressure Sensor - Open Circuit	50011
Input Pressure Sensor - Short Circuit	50012
Interstage Pressure Sensor - Open Circuit	50013
Interstage Pressure Sensor - Short Circuit	50014
Output Pressure Sensor - Open Circuit	50015
Output Pressure Sensor - Short Circuit	50016
Input Pressure Sensor - Invalid Configuration	50017
Interstage Pressure Sensor - Invalid Configuration	50018
Output Pressure Sensor - Invalid Configuration	50019
Input Pressure Sensor - Out of range	50020
Interstage Pressure Sensor - Out of range	50021
Output Pressure Sensor - Out of range	50022
Mguard fault feedback signal	50026
HMI Communication Loss	50027
Timeout actuator commence starting	50029
Timeout actuator enter run state	50029
Enable gas inlet on while not parked	50030
Input Gas High Temperature Error	50037
Cylinder 1 Output Gas High Temperature Error	50038
Cylinder 2 Input Gas High Temperature Error	50039
Internal fault in isolation control	50041
Error occurred changing variant	50042
Temperature Sensor Fault - Input	50047
Temperature Sensor Fault - Cyl1 Out	50048
Temperature Sensor Fault - Cyl2 In	50049
Temperature Sensor Fault - Output	50050
Force Limit Forward Error from Motor	50066
Force Limit Reverse Error from Motor	50068
Net Force Limit Forward Error	50070
Net Force Limit Reverse Error	50072
Force Limit Cylinder 1 Error	50073
Force Limit Cylinder 2 Error	50075

Errors	AlarmCode
Timeout actuator still running on shutdown	50076
Actuator stopped while running unexpectedly	50077
Actuator aborted startup sequence	50081
Low Air Pressure Error	50082
High Air Pressure Error	50084
Internal error in output pressure controller	50085
Oil leak proximity sensor Cylinder 1	50086
Oil leak proximity sensor Cylinder 2	50087
Seal change counter error	50090

Warnings

Warnings	Alarm Code
Inlet Pressure Low Warning	50006
Inlet Pressure Low Speed Limit	50007
Inlet Pressure High Warning	50008
Low Air Pressure Warning	50023
Loss of air pressure while gas on	50024
No coolant flow detected	50025
Pump slowed by cylinder1 output temperature	50031
Pump slowed by cylinder2 output temperature	50032
Input Gas High Temperature Warning	50033
Cylinder 1 Output Gas High Temperature Warning	50034
Cylinder 2 Input Gas High Temperature Warning	50035
Output Gas High Temperature Warning	50036
Output Gas High Temperature Error	50040
High compression ratio Cyl1	50052
High compression ratio Cyl2	50053
High compression ratio In:Out	50054
Interstage pressure low speed limit	50056
Interstage pressure high warning	50057
Interstage pressure high error	50058
Interstage pressure below inlet pressure	50059
Outlet pressure below interstage pressure	50060
Outlet pressure below inlet pressure	50061
Outlet pressure high warning	50062
Outlet pressure high error	50063
Interstage prime timeout	50064
Force Limit Forward Warning from Motor	50065
Force Limit Reverse Warning from Motor	50067
Net Force Limit Forward Warning	50069
Net Force Limit Reverse Warning	50071

Warnings	Alarm Code
Force Limit Cylinder 1 Warning	50073
Force Limit Cylinder 2 Warning	50074
High Air Pressure Warning	50083
Seal change counter warning	50089

Information Message

Information	Alarm Code
Low Pressure Speed Limits Disabled	50010
Variant change triggered	50028
Single fill cycle complete	50043

Haskel[®]



Haskel International, LLC
100 East Graham Place
Burbank CA 91502
USA

Telephone:

818-843-4000

www.haskel.com